



# Beverage Duty, Food Duty, and Poultry Duty MGS® Speed Reducers

STÖBER's MGS® Beverage, Food, and Poultry duty product offerings have become the quality standard for the markets served. These robust solutions for extreme environments leverage precision helical bevel gearing to achieve the highest efficiency, therefore, reducing your operating and maintenance cost. These reducers excel in extremely demanding applications under the harshest washdown environments.

The basic features include:

- Three year warranty.
- Maintenance free.
- Lubricated for life.
- Double sealed output.
- High tensile 300 series stainless steel quill, bushing, shafts, and fasteners.
- Mounts in any position with output shaft horizontal.
- Wash down covers for all output configurations.
- Multilayered industrial strength epoxy coating with 316 stainless steel leafing pigments.

## Company Profile

STÖBER has been a pioneer in the gearing industry since 1934. Through constant innovation, STÖBER today is known for high performance, high efficiency, and low noise, encompassing various gearing solutions offered to the industry. STÖBER® Drives Incorporated, located in Maysville KY, manufactures products for the North American market.

Beginning with the ComTrac® Mechanical Variable Speed Reducer, STÖBER established itself as a technology innovator, later adding the reliable constant speed MGS® series to broaden the product offering. The MGS (Modular Gear System) line provides a large range of available sizes, ratios, mounting flexibility, and extremely responsive delivery options.

STÖBER next introduced ServoFit® Precision Planetary Gearheads – setting the standard for low noise and low backlash in the servo industry. The SMS (ServoFit® Modular System) combines the proven excellence of the MGS system with servo precision to create a cost effective alternative in the servo market.

STÖBER has the broadest product offering available, providing one stop shopping for both the industrial gearing market and the rapidly growing motion control market.

On behalf of the world wide STÖBER Team, we pledge to meet or exceed your product and service needs with continued high quality solutions.

Sincerely,

Bernd Stöber, Chairman  
STÖBER Antriebstechnik GmbH

Peter Feil, VP/General Manager  
STÖBER Drives, Inc.

## Table of Contents

### "K" Series – Beverage Duty and Food Duty

Features .....	2
Double Bushing Unit .....	4
Single Side Output Shaft Unit .....	6
Torque Arm Brackets .....	8
Torque Arm .....	9
Bushing Installation .....	10
Mounting Information .....	12



### "C" Series – Beverage Duty and Food Duty

Features .....	15
Dimensions .....	16



### "F" Series – Poultry Duty

Features .....	18
Dimensions .....	19



### "K" Series – Poultry Duty

Features .....	20
Dimensions .....	21



Mission Statement .....	14
Motor Mounting Instructions .....	22
Terms and Conditions of Sale .....	24

MEX (55) 53 63 23 31 MTY (81) 83 54 10 18  
QRO (442) 1 95 72 60 ventas@industrialmagza.com



# Beverage Duty and Food Duty "K" Series – MGS Helical/Bevel Reducers



The standard "K" Series Helical/Bevel MGS Beverage Duty and Food Duty unit is supplied with a patented double sided wobble free bushing system. This unique design allows the unit to be mounted on the shaft from either side of the reducer (see illustration below).

Featuring a distinct support side and a clamp side, the dual tapered cones will overcome a wide range of tolerances normally found with standard shaft materials. The clamp side is determined by the customer but is usually the outside bushing.

Each case size can be provided with a variety of bushing bore sizes. The unit is selected based on horsepower or torque rating, output speed or ratio, and the shaft size of the driven equipment. The bushing is not installed into the unit at the factory, but with easy to follow assemble instructions, the unit and bushing can be mounted on the machinery quickly – without any special tools. The bore size in the unit can be changed any time during the life of the unit simply by changing the bushing kit.

This unit has several features that make it virtually maintenance free in a **wet** or **dry** environment.

- All quills and bushing parts are high tensile stainless steel—allowing the same torque capacity as the standard MGS unit with the additional benefit of corrosion resistance.
- The output is double sealed on both sides using an outer dual lip seal and an inner single lip seal.
- The NEMA C-face input flange has an O-ring between the reducer and motor.

- Each unit is shipped with Grade 5EP oil filled to the proper level to mount in any position with the output horizontal. Food grade oil can be provided upon request.
- All units are supplied with output covers which protect the seals during washing and also cover the rotating bushings. The outside cover also has an O-ring for added protection.
- Since all units are completely sealed, they are lubricated for life. There is no breather that can allow moisture to enter the unit during high pressure washing.
- All hardware is stainless steel.
- Stainless steel coating – each unit is coated in multiple steps to insure robustness for your demanding applications. This unique coating incorporates 316 stainless steel leafing pigments into the coating. Food Duty units have two additional layers of epoxy coating to achieve the required resistance levels for your extreme washdown conditions. The finish is USDA approved for use in food processing and handling.

In addition, all units can be provided, on request, with a clear coat or white epoxy topcoat which is also USDA approved.

- All STÖBER MGS reducers have a three year warranty.
- "K" Series units can also be supplied for Food and Beverage Duty with a single side stainless steel output shaft.

## Bushing on Both Sides

Interchangeable Support Side and Clamp Side

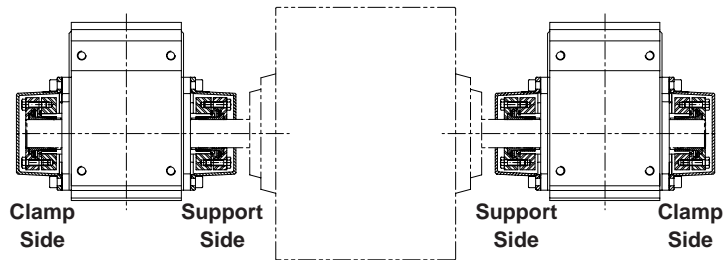

Conveyor with Shaft Either Side

## Comparison

### BEVERAGE DUTY

**Coating:** Industrial 316 Stainless Steel Epoxy

**Output:** Stainless Steel

**Key:** Stainless Steel

**Seals:** Double

- 1- Dual Lip Outer Output Seal
- 1- Single Lip Inner Output Seal

**Hardware:** ALL Stainless Steel

**Lubricant:** Standard (Mobile 630)

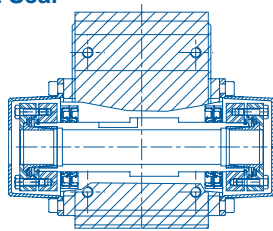

- Options:** Food Grade Oil (Exxon Univis Special Mist 220)  
Synthetic Oil (Mobil SHC630)  
Ultra Clear Industrial Epoxy  
White Epoxy

### FOOD DUTY

Multilayer Industrial 316 Stainless Steel Epoxy

Stainless Steel

Stainless Steel

Double

- 1- Dual Lip Outer Output Seal
- 1- Single Lip Inner Output Seal

ALL Stainless Steel

Standard (Mobile 630)

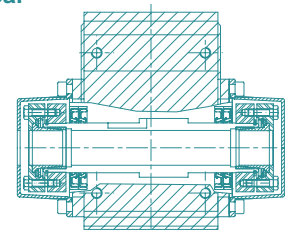

- Options:** Food Grade Oil (Exxon Univis Special Mist 220)  
Synthetic Oil (Mobil SHC630)  
Ultra Clear Industrial Epoxy  
White Epoxy

MTY (81) 83 54 10 18  
ventas@industrialmagza.com

MEX (55) 53 63 23 31  
QRO (442) 1 95 72 60

INDUSTRIAL MAGAZA  
DIST. AUTORIZADO



# Beverage Duty and Food Duty "K" Series – MGS Helical/Bevel Reducers

- Lubricated for Life
- Maintenance Free
- Totally Enclosed (Watertight)
- 3 Year Warranty – your guarantee of our confidence in the MGS (Modular Gear System) line of reducers
- 97% Efficiency – for high quality and reliability plus cost savings in energy and maintenance



- Standard Coating – **Industrial 316 Stainless Steel Epoxy**  
 – **Multilayer Industrial 316 Stainless Steel Epoxy**
- Coating Options – Additional Layer Ultra Clear Industrial Epoxy  
 – White Epoxy

- NEMA C-face Input
- O-ring between the motor and reducer
  - Easy mount maintenance free coupling

Stainless Steel Nameplate

ALL Stainless Steel Hardware

Inside Split Cover Cap – enables easy assembly onto the shaft

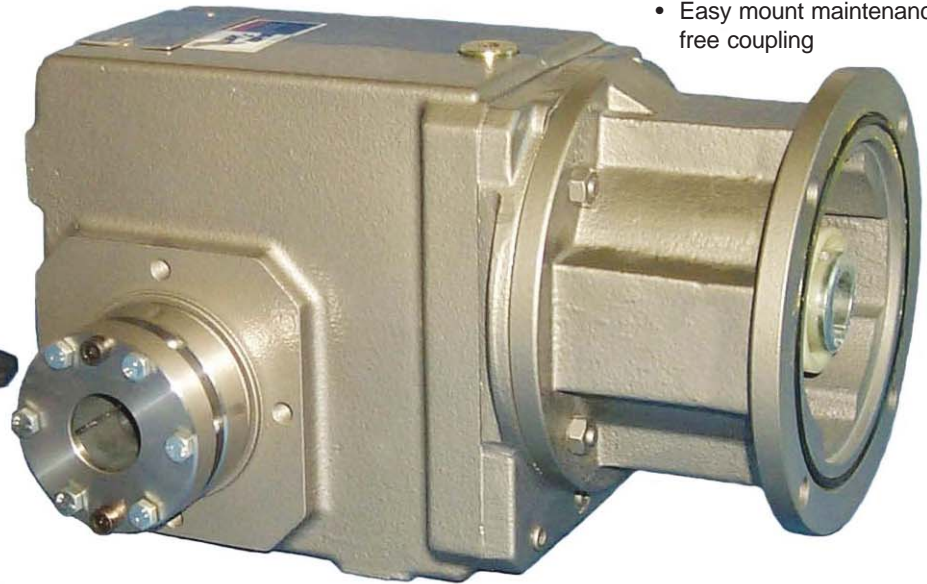

Patented<sup>(1)</sup> Stainless Steel Double Sided Bushing Mounted into Stainless Steel Output Quill – easily mounts onto standard cold finished, ground, or stainless shafting.

Watertight Outside Closed Cover Cap – protects seals from high pressure washing

Double Sealed Output – with a dual lip outer seal and a single lip inner seal

<sup>(1)</sup> U.S. Patent Number 5,496,127

**Indicates Beverage Duty.**  
**Indicates Food Duty.**

## Mounting Positions

One Standard Unit for ALL Horizontal Mounting Positions Without Changing the Oil Level



EL1



EL2



EL5



EL6

Possible but not recommended

MEX (55) 53 63 23 31 MTY (81) 83 54 10 18  
 QRO (442) 1 95 72 60  
 INDUSTRIAL MAGAZA  
 DIST. AUTORIZADO  
 ventas@industrialmagaza.com



# "WFB" – Double Wobble Free Bushing "K" Series – MGS Helical/Bevel Reducer Dimensional Data

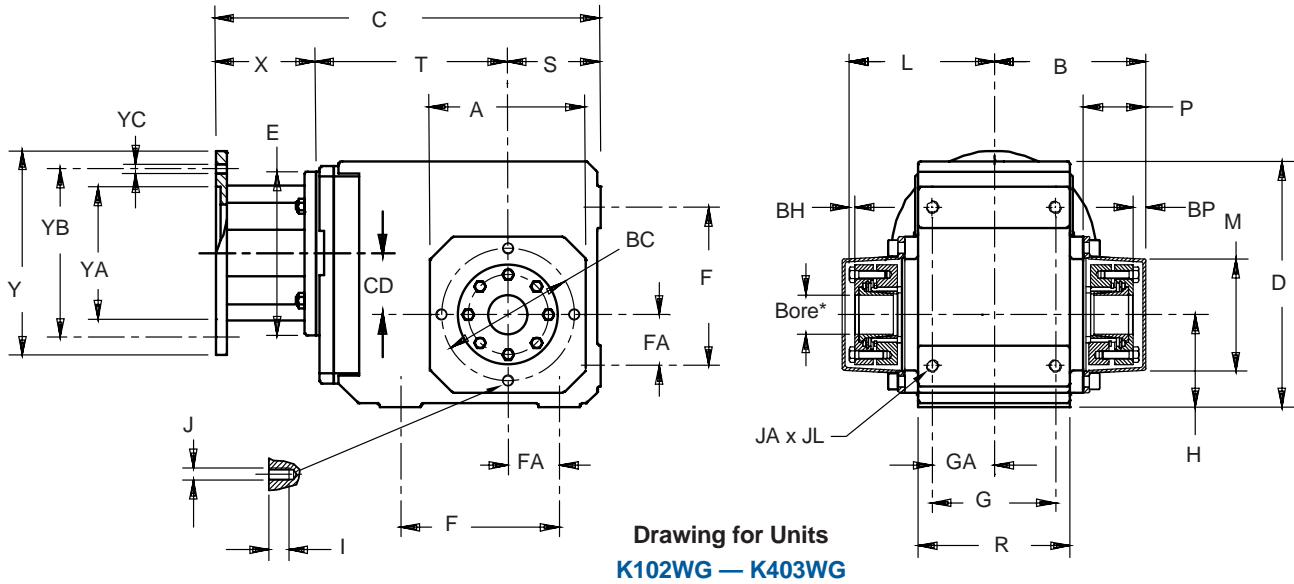

Drawing for Units  
K102WG — K403WG

MTY (81) 83 54 10 18  
 ventas@industrialmagza.com

MEX (55) 53 63 23 31  
 QRO (442) 1 95 72 60



**Table No. 1 "K" Series – Double Wobble Free – Unit Dimensions (Inches)**

Base Module	Max. Bore	A	B	D	F	G	H	I	J	L
K102	1.0000	4.13	3.90	6.30	3.54	2.76	2.36	.51	M8	3.82
K202/203	1.1875	4.57	4.68	7.48	4.53	3.54	2.56	.51	M8	4.45
K302/303	1.5000	5.20	4.98	8.39	5.12	4.13	2.95	.51	M8	4.70
K402/403	1.5000	5.98	5.80	9.45	6.10	4.72	3.54	.63	M10	5.53
K513/514	2.0000	5.71	6.05	10.24	5.51	4.92	6.30	.63	M10	5.81
K613/614	2.1875	7.09	6.61	12.20	6.30	5.12	7.48	.63	M10	6.34
K713/714	2.375	7.68	7.68	13.46	7.09	5.71	8.35	.75	M12	7.53
K813/814	2.750	8.90	9.34	16.14	9.45	7.28	10.43	.75	M12	9.01

**Table No. 2**

Base Module	M	P	R	S	Z <sub>1</sub>	BC	BP	BH	FA	GA	JA	JL
K102	3.07	1.97	3.54	2.36	—	3.54	.24	.16	1.18	1.38	M8	.51
K202/203	3.46	2.05	4.53	2.56	—	3.94	.39	.16	1.38	1.77	M10	.63
K302/303	3.78	2.09	5.12	2.95	—	4.53	.43	.16	1.57	2.07	M10	.63
K402/403	4.33	2.40	5.83	3.54	—	5.12	.47	.20	1.97	2.36	M12	.75
K513/514	4.54	2.40	6.30	3.94	5.98	5.12	.43	.20	1.57	2.46	M16	1.02
K613/614	5.00	2.68	6.61	4.72	6.77	6.50	.51	.24	1.97	2.56	M16	1.02
K713/714	5.75	2.91	7.48	4.92	7.52	7.28	.39	.24	2.17	2.85	M20	1.22
K813/814	6.95	3.43	9.25	5.71	8.11	8.46	.64	.31	2.95	3.64	M24	1.50

**Table No. 3 Motor Adapter Dimensions (Inches)**

Motor Adapter	NEMA C-Flange	E	X	Y	YA	YB	YC	Wt. lbs.
MR140/050B	56C	5.51	3.31	6.50	4.500	5.87	.41	9
MR160/050B	56C	6.30	3.86	6.50	4.500	5.87	.41	16
MR160/140B	143/145TC	6.30	3.86	6.50	4.500	5.87	.41	16
MR200/180B	182/184TC	7.87	4.80	9.00	8.500	7.25	.55	23
MR250/180B	182/184TC	9.84	5.31	9.00	8.500	7.25	.55	36
MR250/210B	213/215TC	9.84	5.31	9.00	8.500	7.25	.55	36
MR300/180B	182/184TC	11.81	6.50	9.00	8.500	7.25	.57	75
MR300/210B	213/215TC	11.81	6.50	9.00	8.500	7.25	.57	75
MR300/250B	254/256TC	11.81	6.50	9.00	8.500	7.25	.57	75
MR300/280B	284/286TC	11.81	6.50	11.13	10.500	9.00	.57	75

\* The bushing will accept a shaft with a tolerance of +.000 / -.005.

**Table No. 4 "WFB" Bushing Kits**

Bushing Kit No.	Bore-inches
WFB1-100	1
WFB2-100	1
WFB2-103	1 <sup>3</sup> / <sub>16</sub>
WFB3-100	1
WFB3-103	1 <sup>3</sup> / <sub>16</sub>
WFB3-104	1 <sup>1</sup> / <sub>4</sub>
WFB3-106	1 <sup>3</sup> / <sub>8</sub>
WFB3-107	1 <sup>7</sup> / <sub>16</sub>
WFB3-108	1 <sup>1</sup> / <sub>2</sub>
WFB4-100	1
WFB4-103	1 <sup>3</sup> / <sub>16</sub>
WFB4-104	1 <sup>1</sup> / <sub>4</sub>
WFB4-106	1 <sup>3</sup> / <sub>8</sub>
WFB4-107	1 <sup>7</sup> / <sub>16</sub>
WFB4-108	1 <sup>1</sup> / <sub>2</sub>
WFB5-107	1 <sup>7</sup> / <sub>16</sub>
WFB5-108	1 <sup>1</sup> / <sub>2</sub>
WFB5-110	1 <sup>5</sup> / <sub>8</sub>
WFB5-111	1 <sup>11</sup> / <sub>16</sub>
WFB5-112	1 <sup>3</sup> / <sub>4</sub>
WFB5-114	1 <sup>7</sup> / <sub>8</sub>
WFB5-115	1 <sup>15</sup> / <sub>16</sub>
WFB5-200	2
WFB6-107	1 <sup>7</sup> / <sub>16</sub>
WFB6-108	1 <sup>1</sup> / <sub>2</sub>
WFB6-110	1 <sup>5</sup> / <sub>8</sub>
WFB6-111	1 <sup>11</sup> / <sub>16</sub>
WFB6-112	1 <sup>3</sup> / <sub>4</sub>
WFB6-115	1 <sup>15</sup> / <sub>16</sub>
WFB6-200	2
WFB6-203	2 <sup>3</sup> / <sub>16</sub>
WFB7-115	1 <sup>15</sup> / <sub>16</sub>
WFB7-200	2
WFB7-203	2 <sup>3</sup> / <sub>16</sub>
WFB7-206	2 <sup>3</sup> / <sub>8</sub>
WFB8-203	2 <sup>3</sup> / <sub>16</sub>
WFB8-206	2 <sup>3</sup> / <sub>8</sub>
WFB8-207	2 <sup>7</sup> / <sub>16</sub>
WFB8-212	2 <sup>3</sup> / <sub>4</sub>
Bushing Kit No.	Bore-Metric
WFB4-40	40mm
WFB5-40	40mm
WFB6-40	40mm





# "WFB" – Double Wobble Free Bushing "K" Series – MGS Helical/Bevel Reducer Dimensional Data

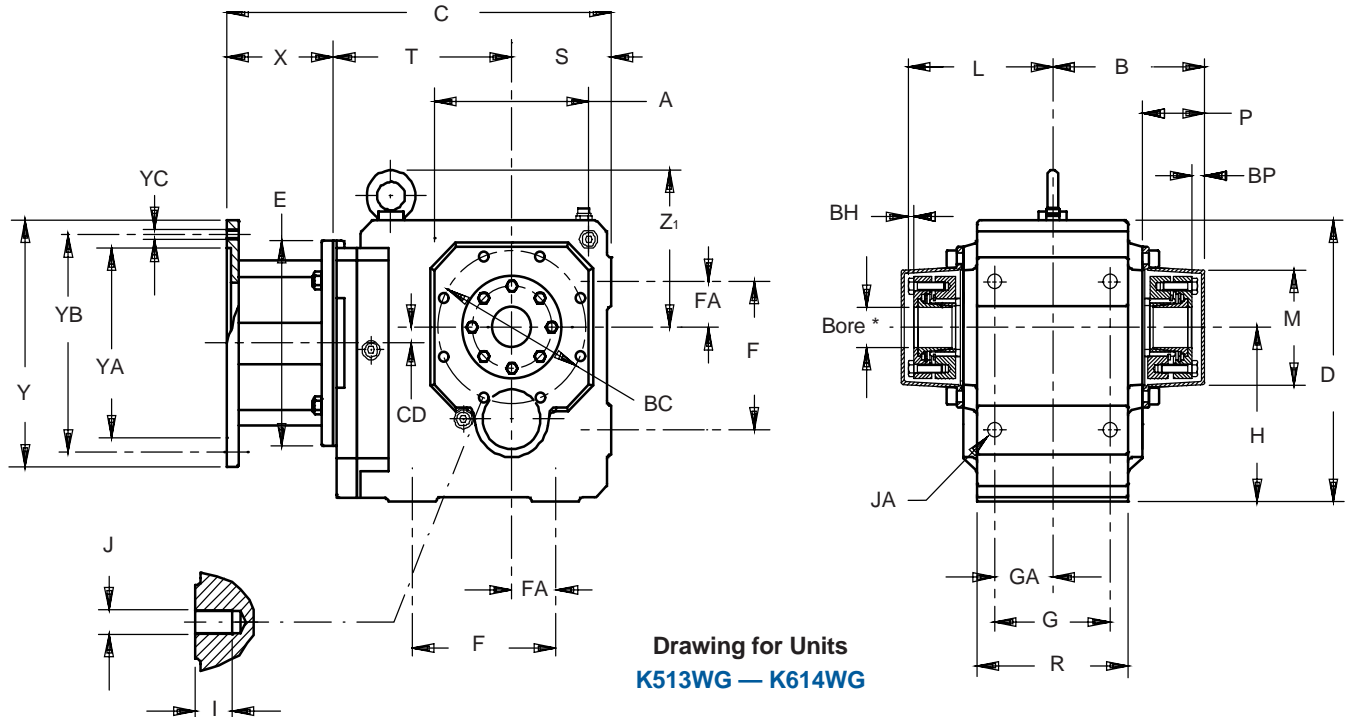

**Table No. 5 "K" Series – Double Wobble Free – Unit Dimensions (Inches)**

Base Module	MR140/050B			MR160/140B <sup>1)</sup>			MR200/180B			MR250/210B <sup>2)</sup>			MR300/250B <sup>3)</sup>			Wt. lbs.
	CD	C	T	CD	C	T	CD	C	T	CD	C	T	CD	C	T	
K102	1.42	10.55	4.88	1.42	11.26	5.04	—	—	—	—	—	—	—	—	—	31
K202	1.81	11.50	5.63	1.81	12.21	5.79	1.81	13.23	5.87	—	—	—	—	—	—	40
K203	1.81	12.96	7.09	—	—	—	—	—	—	—	—	—	—	—	—	53
K302	2.07	12.68	6.42	2.07	13.38	6.57	2.07	14.40	6.65	—	—	—	—	—	—	67
K303	2.07	14.13	7.87	.63	15.08	8.27	—	—	—	—	—	—	—	—	—	73
K402	—	—	—	2.36	14.76	7.36	2.36	15.74	7.44	2.36	16.41	7.56	—	—	—	93
K403	2.36	15.51	8.66	.91	16.46	9.06	—	—	—	—	—	—	—	—	—	100
K513	—	—	—	.59	14.57	6.77	.59	15.59	6.85	.59	16.22	6.97	—	—	—	106
K514	—	—	—	.59	16.26	8.46	—	—	—	—	—	—	—	—	—	109
K613	—	—	—	.71	16.10	7.52	.71	17.12	7.60	.71	17.75	7.72	.71	19.49	8.27	170
K614	—	—	—	.71	17.79	9.21	—	—	—	—	—	—	—	—	—	177
K713	—	—	—	—	—	—	.79	18.42	8.70	.79	19.05	8.82	.79	20.75	9.33	221
K714	—	—	—	.79	19.13	10.35	.79	20.86	11.14	—	—	—	—	—	—	234
K813	—	—	—	—	—	—	.94	20.23	9.72	.94	20.82	9.80	.94	22.52	10.31	309
K814	—	—	—	—	—	—	.94	22.64	12.13	—	—	—	—	—	—	331

<sup>1)</sup> Also available as **MR160/050B** for a NEMA 56C frame motor.  
<sup>2)</sup> Also available as **MR250/180B** for a NEMA 182/184TC frame motor.  
<sup>3)</sup> Also available as **MR300/180B** for a NEMA 182/184TC, **MR300/210B** for a NEMA 213/215TC, and **MR300/280B** for a NEMA 284/286TC frame motor.  
 All weights are approximate.

**Part No. Example**

Beverage Duty Unit  
 with 143TC Frame Motor Adapter and 1<sup>7</sup>/<sub>16</sub> Bushing Bore  
**K303WG0650 MR160/140B WFB3-107**

**Table No. 6 "WFB" Bushing – Stock Bores**

Base Module	INCHES															METRIC 40mm	
	1	1 <sup>3</sup> / <sub>16</sub>	1 <sup>1</sup> / <sub>4</sub>	1 <sup>3</sup> / <sub>8</sub>	1 <sup>7</sup> / <sub>16</sub>	1 <sup>1</sup> / <sub>2</sub>	1 <sup>5</sup> / <sub>8</sub>	1 <sup>11</sup> / <sub>16</sub>	1 <sup>3</sup> / <sub>4</sub>	1 <sup>7</sup> / <sub>8</sub>	1 <sup>15</sup> / <sub>16</sub>	2	2 <sup>3</sup> / <sub>16</sub>	2 <sup>3</sup> / <sub>8</sub>	2 <sup>7</sup> / <sub>16</sub>		2 <sup>3</sup> / <sub>4</sub>
K102	x	—	—	—	—	—	—	—	—	—	—	—	—	—	—	—	—
K202/K203	x	x	—	—	—	—	—	—	—	—	—	—	—	—	—	—	—
K302/K303	x	x	x	x	x	x	—	—	—	—	—	—	—	—	—	—	—
K402/K403	x	x	x	x	x	x	—	—	—	—	—	—	—	—	—	—	x
K513/K514	—	—	—	—	x	x	x	x	x	x	x	x	—	—	—	—	x
K613/K614	—	—	—	—	x	x	x	x	x	—	x	x	x	—	—	—	x
K713/K714	—	—	—	—	—	—	—	—	—	—	x	x	x	x	—	—	—
K813/K814	—	—	—	—	—	—	—	—	—	—	—	—	x	x	x	x	—

MEX (55) 53 63 23 31 MTY (81) 83 54 10 18  
 QRO (442) 1 95 72 60 ventas@industrialmagza.com  
**INDUSTRIAL MAGAZA**  
 DIST. AUTORIZADO

# Single Side Output Shaft "K" Series – MGS Helical/Bevel Reducer Dimensional Data

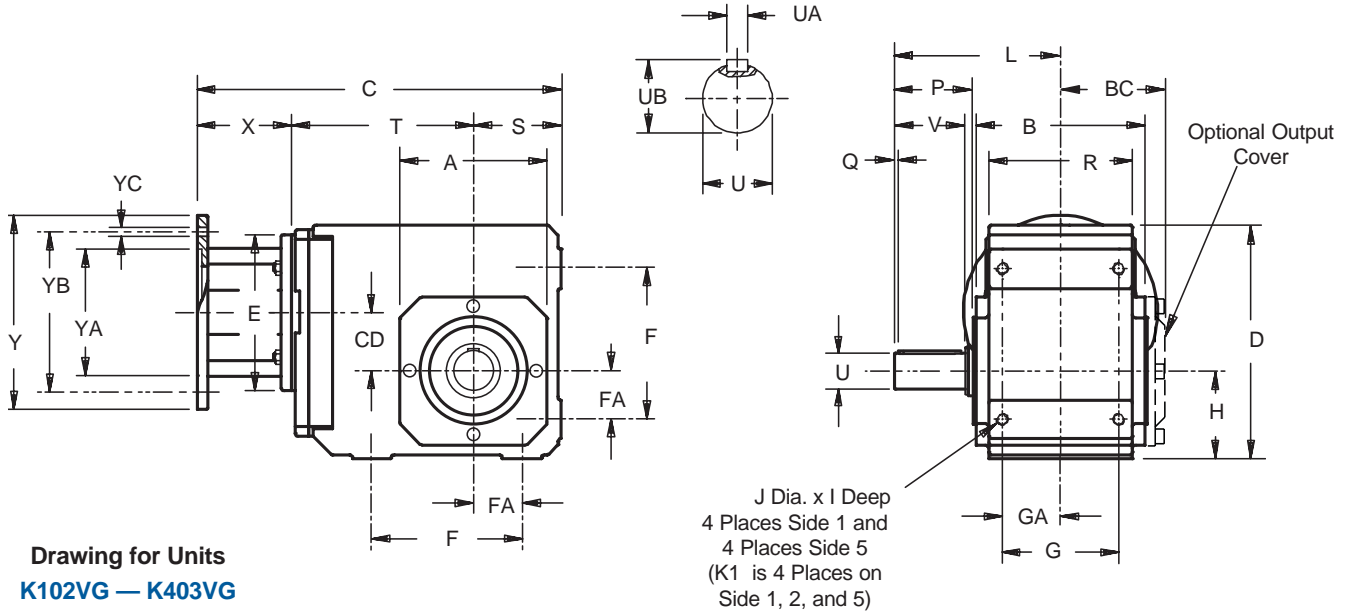

**Table No. 1 "K" Series – Unit Dimensions (Inches) – "G" Housing Style**

Base Module	A	B	BC	D	F	FA	G	GA	H	I	J	L	O	P	R
<b>K102</b>	4.13	4.17	2.64	6.30	3.54	1.18	2.76	1.38	2.36	.51	M8	4.53	—	2.32	3.54
<b>K202/203</b>	4.57	5.28	3.23	7.48	4.53	1.38	3.54	1.77	2.56	.63	M10	5.31	—	2.56	4.53
<b>K302/303</b>	5.20	5.75	3.46	8.39	5.12	1.57	4.13	2.07	2.95	.63	M10	5.59	—	2.60	5.12
<b>K402/403</b>	5.98	6.81	4.08	9.45	6.10	1.97	4.72	2.36	3.54	.75	M12	6.54	—	3.39	5.83
<b>K513/514</b>	5.71	7.28	4.31	10.24	5.51	1.57	4.92	2.46	6.30	1.02	M16	8.74	5.10	3.90	6.30
<b>K613/614</b>	7.09	7.87	4.61	12.20	6.30	1.97	5.12	2.56	7.48	1.02	M16	9.29	5.35	4.31	6.61
<b>K713/714</b>	7.68	8.90	5.08	13.46	7.09	2.17	5.71	2.85	8.35	1.22	M20	10.91	6.46	5.14	7.48
<b>K813/814</b>	8.90	11.10	6.26	16.14	9.45	2.95	7.28	3.64	10.43	1.50	M24	12.83	7.28	5.94	9.25

**Table No. 2**

Base Module	Q	S	U	UA – Key	UB	V	Z <sub>1</sub>
<b>K102</b>	.16	2.36	1.000	1/4 x 1/4 x 1 <sup>9</sup> / <sub>16</sub>	1.11	1.97	—
<b>K202/203</b>	.16	2.56	1.250	1/4 x 1/4 x 1 <sup>15</sup> / <sub>16</sub>	1.36	2.36	—
<b>K302/303</b>	.16	2.95	1.250	1/4 x 1/4 x 1 <sup>15</sup> / <sub>16</sub>	1.36	2.36	—
<b>K402/403</b>	.16	3.54	1.375	5/16 x 5/16 x 2 <sup>5</sup> / <sub>16</sub>	1.51	2.76	—
<b>K513/514</b>	.16	3.94	1.750	3/8 x 3/8 x 3 <sup>5</sup> / <sub>32</sub>	1.92	3.54	5.98
<b>K613/614</b>	.16	4.72	1.750	3/8 x 3/8 x 3 <sup>5</sup> / <sub>32</sub>	1.92	3.94	6.77
<b>K713/714</b>	.16	4.92	2.375	5/8 x 5/8 x 3 <sup>15</sup> / <sub>16</sub>	2.65	4.72	7.52
<b>K813/814</b>	.20	5.71	2.875	3/4 x 3/4 x 4 <sup>5</sup> / <sub>16</sub>	3.21	5.51	8.11

**Table No. 3 Motor Adapter Dimensions (Inches)**

Motor Adapter	NEMA C-Flange	E	X	Y	YA	YB	YC	Wt. lbs.
<b>MR140/050B</b>	56C	5.51	3.31	6.50	4.500	5.87	.41	9
<b>MR160/050B</b>	56C	6.30	3.86	6.50	4.500	5.87	.41	16
<b>MR160/140B</b>	143/145TC	6.30	3.86	6.50	4.500	5.87	.41	16
<b>MR200/180B</b>	182/184TC	7.87	4.80	9.00	8.500	7.25	.55	23
<b>MR250/180B</b>	182/184TC	9.84	5.31	9.00	8.500	7.25	.55	36
<b>MR250/210B</b>	213/215TC	9.84	5.31	9.00	8.500	7.25	.55	36
<b>MR300/180B</b>	182/184TC	11.81	6.50	9.00	8.500	7.25	.57	75
<b>MR300/210B</b>	213/215TC	11.81	6.50	9.00	8.500	7.25	.57	75
<b>MR300/250B</b>	254/256TC	11.81	6.50	9.00	8.500	7.25	.57	75
<b>MR300/280B</b>	284/286TC	11.81	6.50	11.13	10.500	9.00	.57	75



# Single Side Output Shaft "K" Series – MGS Helical/Bevel Reducer Dimensional Data

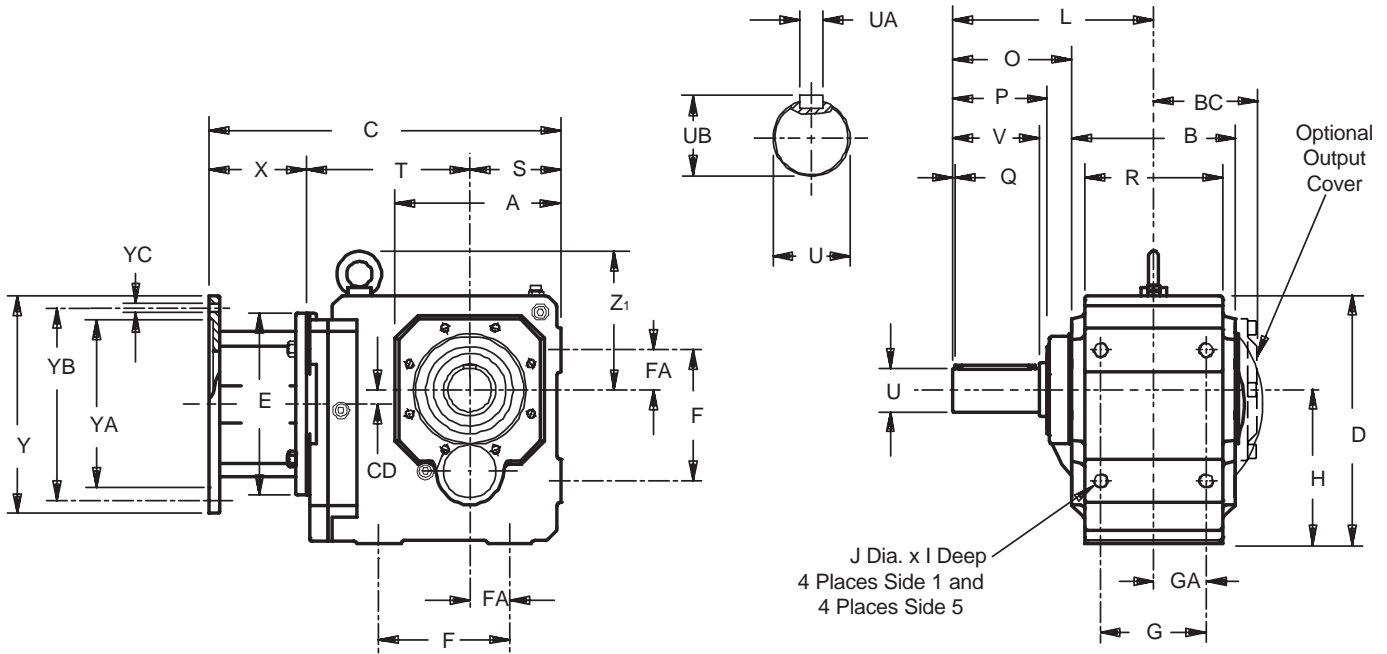

Drawing for Units  
**K513VG — K814VG**

Table No. 4 "K" Series – Unit Dimensions (Inches)

Base Module	MR140/050B			MR160/140B <sup>1)</sup>			MR200/180B			MR250/210B <sup>2)</sup>			MR300/250B <sup>3)</sup>			Wt. lbs.
	CD	C	T	CD	C	T	CD	C	T	CD	C	T	CD	C	T	
<b>K102</b>	1.42	10.55	4.88	1.42	11.26	5.04	—	—	—	—	—	—	—	—	—	31
<b>K202</b>	1.81	11.50	5.63	1.81	12.21	5.79	1.81	13.23	5.87	—	—	—	—	—	—	40
<b>K203</b>	1.81	12.96	7.09	—	—	—	—	—	—	—	—	—	—	—	—	53
<b>K302</b>	2.07	12.68	6.42	2.07	13.38	6.57	2.07	14.40	6.65	—	—	—	—	—	—	67
<b>K303</b>	2.07	14.13	7.87	.63	15.08	8.27	—	—	—	—	—	—	—	—	—	73
<b>K402</b>	—	—	—	2.36	14.76	7.36	2.36	15.74	7.44	2.36	16.41	7.56	—	—	—	93
<b>K403</b>	2.36	15.51	8.66	.91	16.46	9.06	—	—	—	—	—	—	—	—	—	100
<b>K513</b>	—	—	—	.59	14.57	6.77	.59	15.59	6.85	.59	16.22	6.97	—	—	—	106
<b>K514</b>	—	—	—	.59	16.26	8.46	—	—	—	—	—	—	—	—	—	109
<b>K613</b>	—	—	—	.71	16.10	7.52	.71	17.12	7.60	.71	17.75	7.72	.71	19.49	8.27	170
<b>K614</b>	—	—	—	.71	17.79	9.21	—	—	—	—	—	—	—	—	—	177
<b>K713</b>	—	—	—	—	—	—	.79	18.42	8.70	.79	19.05	8.82	.79	20.75	9.33	221
<b>K714</b>	—	—	—	.79	19.13	10.35	.79	20.86	11.14	—	—	—	—	—	—	234
<b>K813</b>	—	—	—	—	—	—	.94	20.23	9.72	.94	20.82	9.80	.94	22.52	10.31	309
<b>K814</b>	—	—	—	—	—	—	.94	22.64	12.13	—	—	—	—	—	—	331

<sup>1)</sup> Also available as **MR160/050B** for a NEMA 56C frame motor.

<sup>2)</sup> Also available as **MR250/180B** for a NEMA 182/184TC frame motor.

<sup>3)</sup> Also available as **MR300/180B** for a NEMA 182/184TC, **MR300/210B** for a NEMA 213/215TC, and **MR300/280B** for a NEMA 284/286TC frame motor.

All weights are approximate.

### Part No. Example

Beverage Duty Unit  
with 143TC Frame Motor Adapter and Output Shaft  
**K303VG0650 MR160/140B**  
Specify Shaft Side 3 or Side 4  
(Drawings above are Shaft Side 3)

See the MGS catalog for other [housing styles](#).

# "K" Series – MGS Helical/Bevel Reducer Torque Arm Bracket

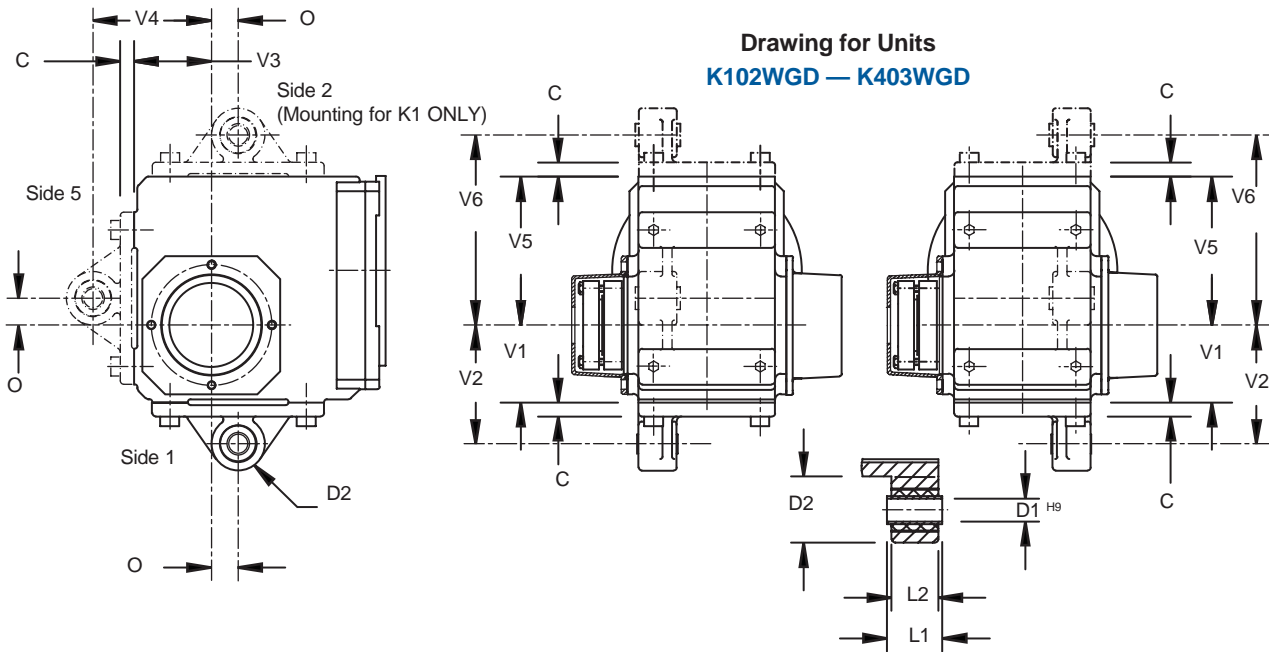

**Table No. 1 "BD" Dimensions (Inches)**

Base Module	C	D1	H9	D2	L1	L2	O	V1	V2	V3	V4	V5	V6
<b>K102</b>	.39	.47	+0.017/-0.000	1.69	1.10	.94	.59	2.36	3.54	2.36	3.54	3.93	5.12
<b>K202/K203</b>	.47	.63	+0.017/-0.000	1.77	1.50	1.26	.89	2.56	3.93	2.56	3.93	—	—
<b>K302/K303</b>	.47	.63	+0.017/-0.000	1.77	1.50	1.26	.98	2.95	4.72	2.95	4.72	—	—
<b>K402/K403</b>	.55	.79	+0.020/-0.000	2.17	1.81	1.57	1.08	3.54	5.91	3.54	5.91	—	—
<b>K513/K514</b>	.59	.79	+0.020/-0.000	2.28	1.81	1.57	1.18	6.30	9.84	3.93	7.48	—	—
<b>K613/K614</b>	.59	.79	+0.020/-0.000	2.28	1.81	1.57	1.18	7.48	9.84	4.72	7.09	—	—
<b>K713/K714</b>	.67	.79	+0.020/-0.000	2.68	2.76	2.52	1.38	8.35	11.81	4.92	8.39	—	—
<b>K813/K814</b>	.67	.94	+0.024/-0.000	2.83	4.53	4.02	1.77	10.43	13.78	5.71	9.06	—	—

The bracket as shown can be mounted on the top side (Side 2) of K102 ONLY.  
All brackets can be mounted on all units K102 through K814 on Side 1 and Side 5.

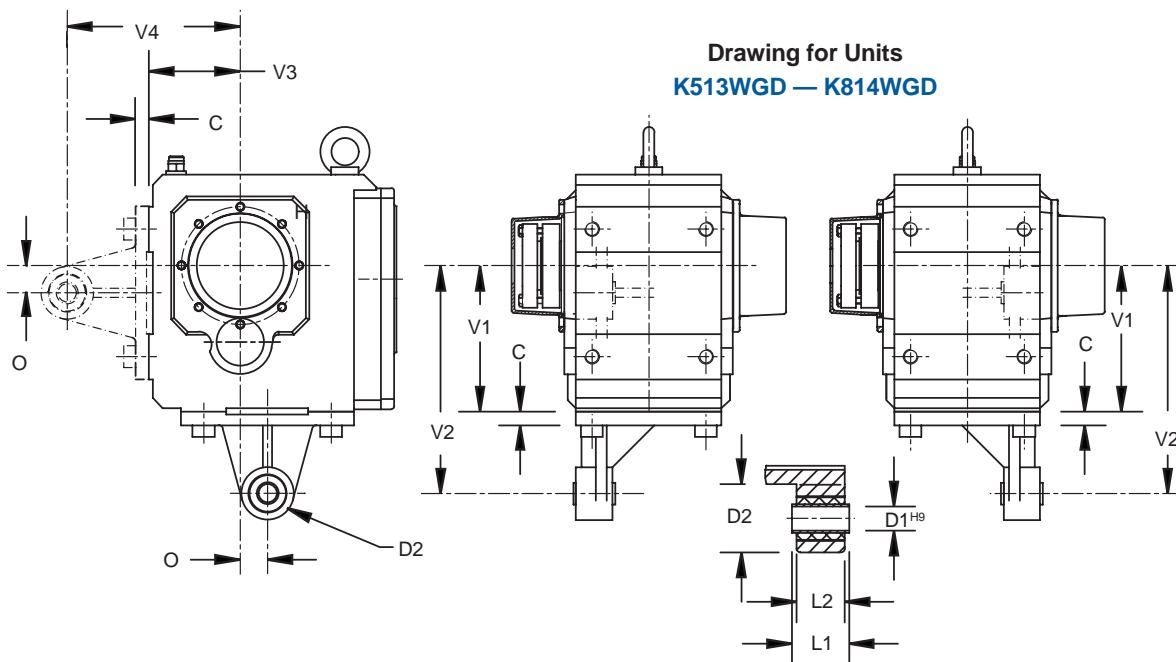





# "K" Series – MGS Helical/Bevel Reducer Torque Arm

Torque Arm design for reference ONLY. (Not supplied by STÖBER.)

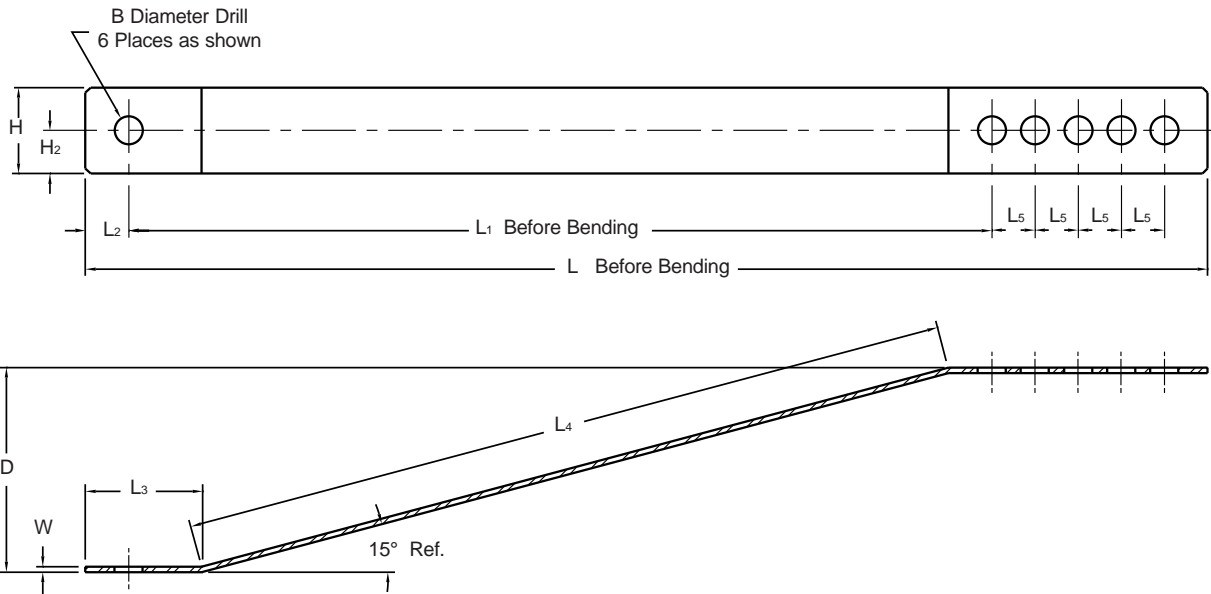
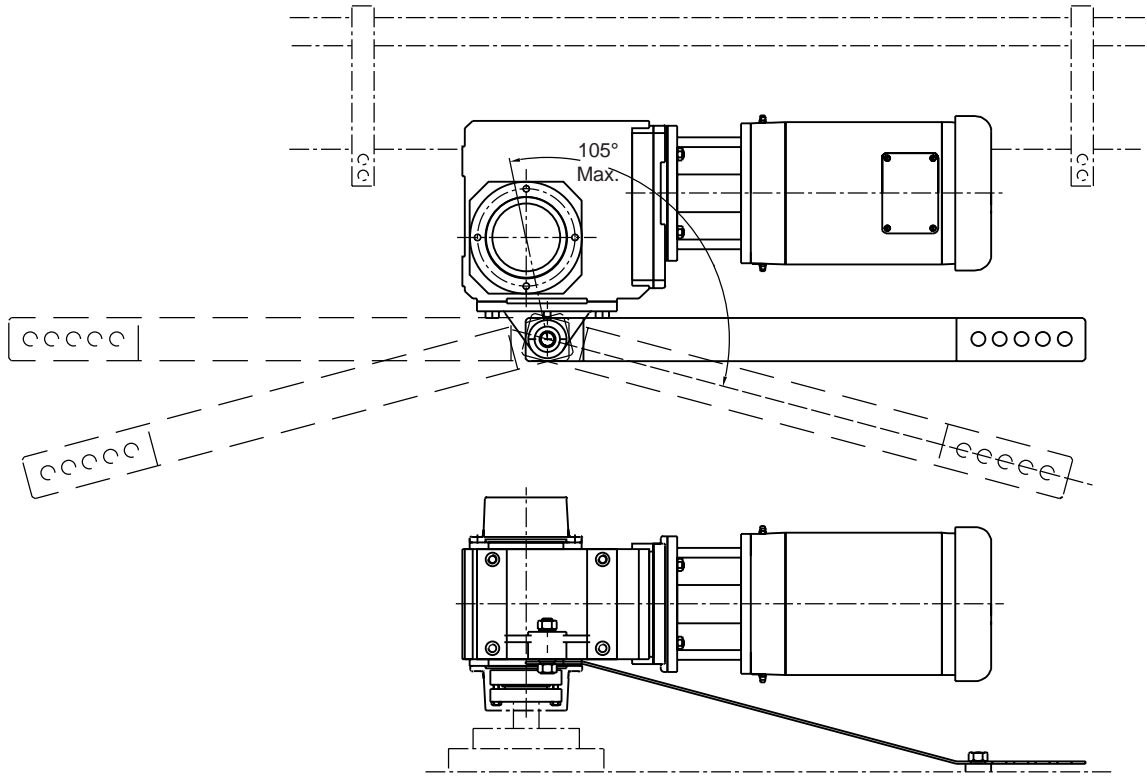

**Table No. 1 Torque Arm Dimensions (Inches)**

Base Module	B	D	H	H <sub>2</sub>	L	L <sub>1</sub>	L <sub>2</sub>	L <sub>3</sub>	L <sub>4</sub>	L <sub>5</sub>	W	Capscrews Size
<b>K102</b>	1/2	4 <sup>3</sup> / <sub>4</sub>	2	1	27	21	1	2 <sup>11</sup> / <sub>16</sub>	17 <sup>15</sup> / <sub>16</sub>	1	1/8	1/2-13 x 2
<b>K202/K203</b>	3/4	4 <sup>3</sup> / <sub>4</sub>	2	1	27	21	1	2 <sup>11</sup> / <sub>16</sub>	17 <sup>15</sup> / <sub>16</sub>	1	1/8	5/8-11 x 2 <sup>3</sup> / <sub>8</sub>
<b>K302/K303</b>	1 <sup>1</sup> / <sub>16</sub>	4 <sup>3</sup> / <sub>4</sub>	2	1	27	21	1	2 <sup>11</sup> / <sub>16</sub>	17 <sup>15</sup> / <sub>16</sub>	1	1/8	5/8-11 x 2 <sup>3</sup> / <sub>8</sub>
<b>K402/K403</b>	1 <sup>3</sup> / <sub>16</sub>	5 <sup>5</sup> / <sub>16</sub>	2	1	31	25	1	2 <sup>11</sup> / <sub>16</sub>	19 <sup>3</sup> / <sub>4</sub>	1	3/16	3/4-10 x 2 <sup>7</sup> / <sub>8</sub>
<b>K513/K514</b>	1 <sup>3</sup> / <sub>16</sub>	5 <sup>5</sup> / <sub>16</sub>	2	1	31	25	1	2 <sup>11</sup> / <sub>16</sub>	19 <sup>3</sup> / <sub>4</sub>	1	3/16	3/4-10 x 2 <sup>7</sup> / <sub>8</sub>
<b>K613/K614</b>	1 <sup>3</sup> / <sub>16</sub>	5 <sup>5</sup> / <sub>16</sub>	2	1	31	25	1	2 <sup>11</sup> / <sub>16</sub>	19 <sup>3</sup> / <sub>4</sub>	1	3/16	3/4-10 x 2 <sup>7</sup> / <sub>8</sub>
<b>K713/K714</b>	1 <sup>3</sup> / <sub>16</sub>	6 <sup>5</sup> / <sub>16</sub>	2	1	31	25	1	2 <sup>11</sup> / <sub>16</sub>	19 <sup>3</sup> / <sub>4</sub>	1	3/16	3/4-10 x 3 <sup>3</sup> / <sub>4</sub>
<b>K813/K814</b>	1 <sup>5</sup> / <sub>16</sub>	6 <sup>5</sup> / <sub>16</sub>	3	1 <sup>1</sup> / <sub>2</sub>	35	27 <sup>1</sup> / <sub>4</sub>	1 <sup>1</sup> / <sub>2</sub>	3 <sup>3</sup> / <sub>16</sub>	24 <sup>5</sup> / <sub>16</sub>	2	1/4	7/8-9 x 5 1/2

# "WFB" – Double Wobble Free Bushing "K" Series – MGS Helical/Bevel Reducer Installation – Part 1

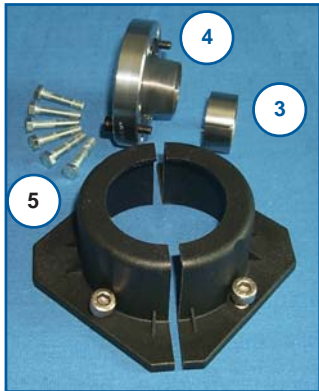

Support Side  
Bushing Components

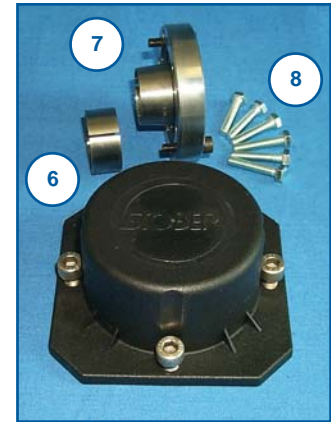

Clamp Side  
Bushing Components

The Support Side is the bushing with the coating on the cone. Do NOT use cleaner on the coated cone.

## Support Side Installation



Insert Tapered Cone



Install Flanged Cone Assembly

Install the Flanged Cone Assembly (4) with it's slot opposite the slot in the tapered cone (3).



Hand Tighten Capscrews

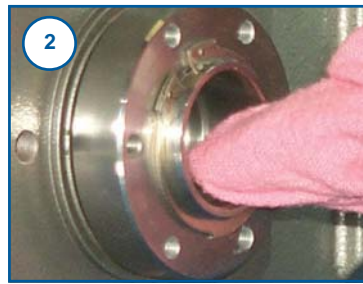

Be sure the inside of the quill is free of grease and oil before installing the tapered cones.

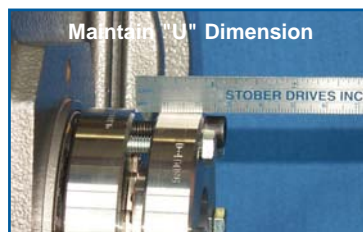

The "U" distance (between the rings) determined by the spacer bolts (see Table 1, Page 11) must be maintained throughout assembly of the bushing and mounting onto the shaft. Therefore DO NOT tighten the capscrews or remove the spacer bolts until the unit is mounted on the shaft.



## Clamp Side Installation



Insert Tapered Cone



Install Flanged Cone Assembly

Install the Flanged Cone Assembly (7) with it's slot opposite the slot in the tapered cone (6).



Hand Tighten Capscrews

MTY (81) 83 54 10 18  
ventas@industrialmagza.com

MEX (55) 53 63 23 31  
QRO (442) 1 95 72 60

**INDUSTRIAL MAGAZA**  
DIST. AUTORIZADO





# "WFB" – Double Wobble Free Bushing "K" Series – MGS Helical/Bevel Reducer Installation – Part 2

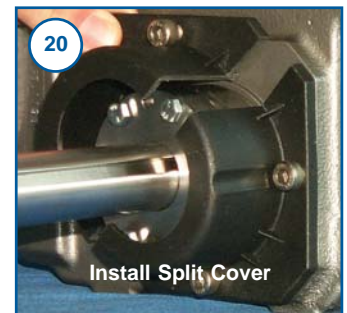
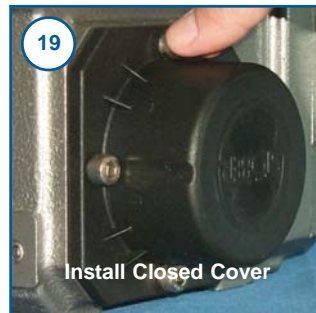

Tighten all capscrews to the torque shown in Table 1. Use a torque wrench. The tightening should be done gradually in a rotating sequence and will require more than one rotation.

After two hours (minimum) running time, check capscrews and retighten, if necessary.



Table No. 1

Base Module	Capscrews		Tightening Torque		U		Spacer Bolts
	Qty.	Size x Length	Nm.	in. lbs.	mm	ins.	
K102	6	M6x25 mm	10	89	5	.20	M6x20mm
K202/K203	6	M6x30 mm	10	89	5	.20	M6x20mm
K302/K303	8	M6x30 mm	10	89	5	.20	M6x20mm
K402/K403	8	M8x30 mm	25	221	6	.24	M8x20mm
K513/K514	8	M8x30 mm	25	221	7	.28	M8x25mm
K613/K614	8	M10x35 mm	49	434	8.5	.33	M10x25mm
K713/K714	8	M10x40mm	49	434	5.5	.22	M10x25mm
K813/K814	8	M12x40mm	85	752	7	.28	M12x45mm

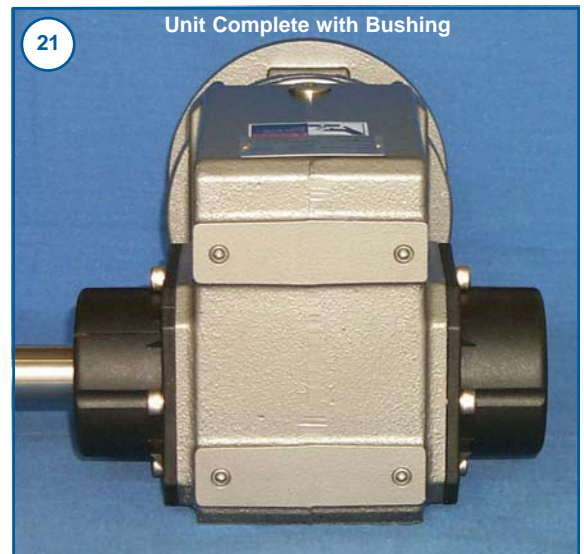

MEX (55) 53 63 23 31 MTY (81) 83 54 10 18  
 QRO (442) 1 95 72 60 ventas@industrialmagza.com  
**INDUSTRIAL MAGAZA**  
 DIST. AUTORIZADO

# "WFB" – Double Wobble Free Bushing "K" Series – MGS Helical/Bevel Reducer Mounting Information

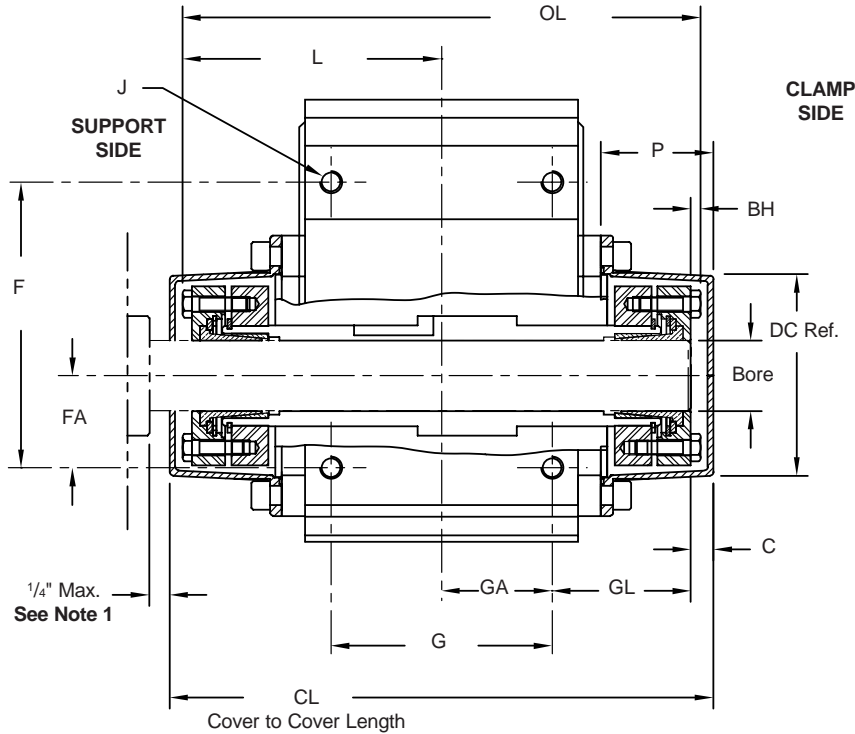

**Important:** A  $1/32 \times 45^\circ$  chamfer minimum is recommended for the shaft end.

**NOTE 1:** The distance shown is the maximum allowable shaft exposure that will meet safety standards. To disengage the bushing from the shaft with the back off bolts may require a distance of  $1/4$ .

**Table No. 1** Mounting Dimensions (Inches)

Base Module	BH	C	CL	DC	F	FA	G	GA	GL	J	L	OL	P
<b>K102</b>	.16	.24	7.80	3.07	3.54	1.18	2.76	1.38	2.28	M8	3.82	7.64	1.97
<b>K202/K203</b>	.16	.39	9.36	3.46	4.53	1.38	3.54	1.77	2.52	M10	4.45	8.90	2.05
<b>K302/K303</b>	.16	.43	9.95	3.78	5.12	1.57	4.13	2.07	2.47	M10	4.70	9.41	2.09
<b>K402/K403</b>	.20	.47	11.60	4.33	6.10	1.97	4.72	2.36	2.97	M12	5.53	11.06	2.40
<b>K513/K514</b>	.20	.43	12.09	4.54	5.51	1.57	4.92	2.46	3.15	M16	5.81	11.63	2.40
<b>K613/K614</b>	.24	.51	13.22	5.00	6.30	1.97	5.12	2.56	3.54	M16	6.34	12.68	2.68
<b>K713/K714</b>	.24	.39	15.36	5.75	7.09	2.17	5.71	2.85	4.12	M20	7.53	15.06	2.91
<b>K813/K814</b>	.31	.64	18.68	6.95	9.45	2.95	7.28	3.64	4.70	M24	9.01	18.02	3.43



The STÖBER Difference . . . .  
. . . . Equals VALUE for you

# 3 Rings

To get competent,  
“one-stop” shopping!

STANDARD  
**3-DAY**  
DELIVERY

**3 YEAR WARRANTY**  
Your guarantee from the proven  
performance of our MGS product line.



## **3 WAY** After Sale Service

**5 Day Factory Service**

**Field Service**

**Training Support**

INDUSTRIAL **MAGAZA**  
DIST. AUTORIZADO  
MEX (55) 53 63 23 31 MTY (81) 83 54 10 18  
CRO (442) 1 95 72 60 ventas@industrialmagza.com



*"we don't say we're best...our customers do"*



**MISSION:**

***To provide the most reliable and effective drive solutions for demanding applications in the shortest lead-time.***



# Beverage Duty and Food Duty "C" Series – MGS Helical Concentric Reducers

- Lubricated for Life
- Maintenance Free
- Totally Enclosed (Watertight)
- 3 Year Warranty – your guarantee of our confidence in the MGS (Modular Gear System) line of reducers
- 97% Efficiency – for high quality and reliability plus cost savings in energy and maintenance

Stainless Steel  
Nameplate

Standard Coating – **Industrial 316 Stainless Steel Epoxy**  
– **Multilayer Industrial 316 Stainless Steel Epoxy**  
Coating Options – Additional Layer Ultra Clear Industrial Epoxy  
– White Epoxy

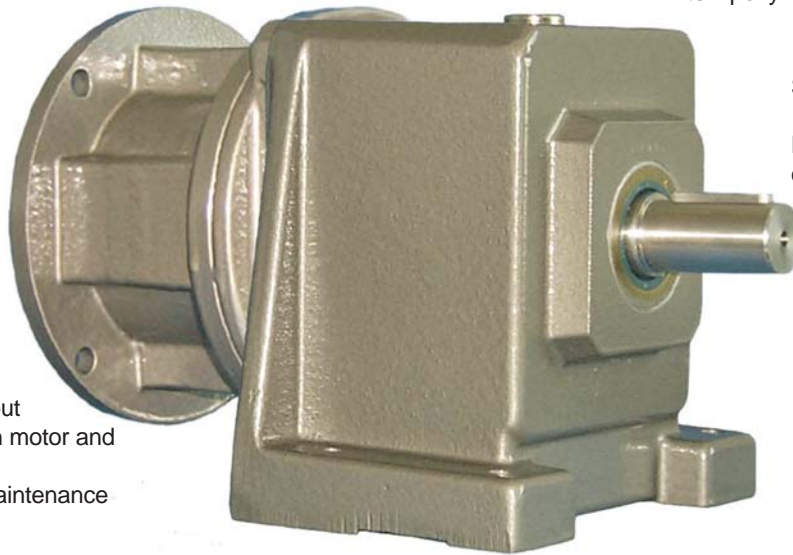

Stainless Steel Output Shaft and Key  
Double Sealed Output – with a dual lip outer seal and a single lip inner seal

NEMA C-face Input

- O-ring between motor and reducer
- Easy mount maintenance free coupling

**Indicates Beverage Duty.**  
**Indicates Food Duty.**

## Mounting Positions

One Standard Unit for ALL Horizontal Mounting Positions  
Without Changing the Oil Level



Can be supplied on request.  
Be sure to specify when ordering.



but not recommended.

## Comparison

### BEVERAGE DUTY

Coating: **Industrial 316 Stainless Steel Epoxy**  
Shaft: **Stainless Steel**  
Key: **Stainless Steel**  
Seals: **Double**  
1- Dual Lip Outer Output Seal  
1- Single Lip Inner Output Seal  
Hardware: **ALL Stainless Steel**  
Lubricant: **Standard (Mobile 630)**

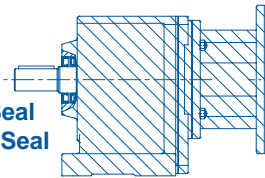

### FOOD DUTY

Multilayer Industrial 316 Stainless Steel Epoxy  
Stainless Steel  
Stainless Steel  
Double  
1- Dual Lip Outer Output Seal  
1- Single Lip Inner Output Seal  
ALL Stainless Steel  
Standard (Mobile 630)

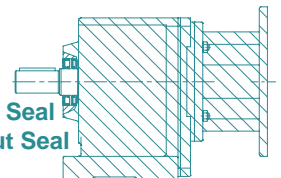

Options: **Food Grade Oil (Exxon Univis Special Mist 220)**  
**Synthetic Oil (Mobil SHC630)**  
**Ultra Clear Industrial Epoxy**  
**White Epoxy**

**Food Grade Oil (Exxon Univis Special Mist 220)**  
**Synthetic Oil (Mobil SHC630)**  
**Ultra Clear Industrial Epoxy**  
**White Epoxy**





# "C" Series—MGS Concentric/Helical Reducer Dimensional Data

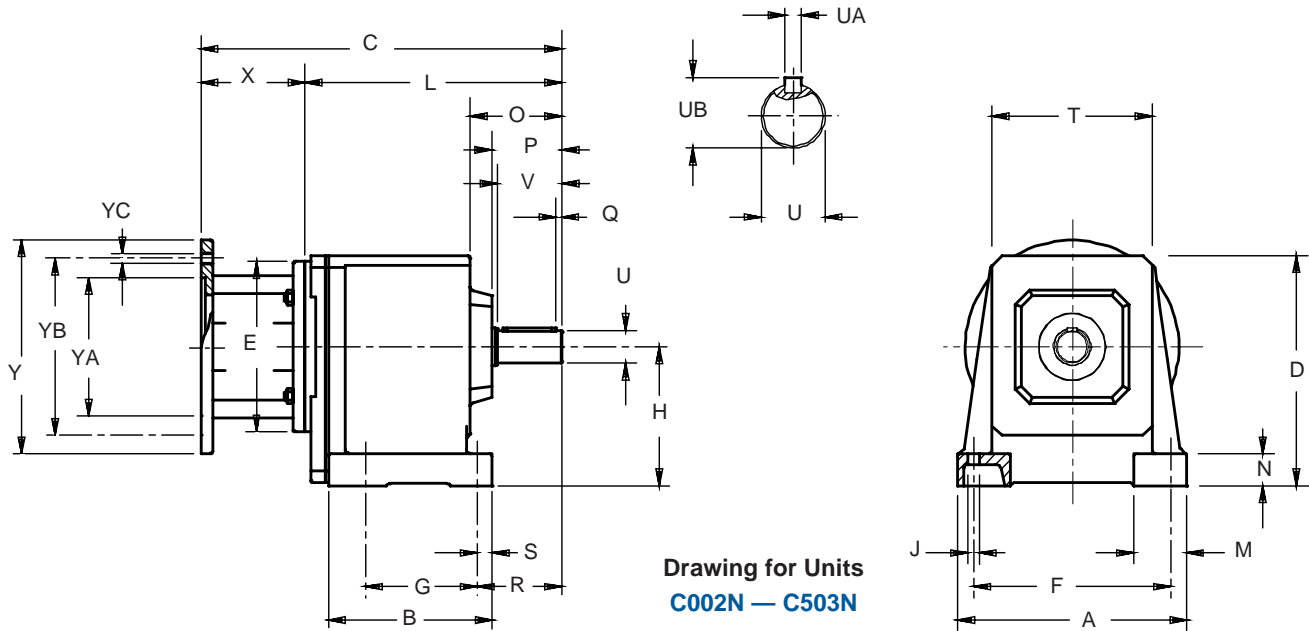

Drawing for Units  
C002N — C503N

**Table No. 1** "C" Series – Foot Mounting Unit Dimensions (Inches) – "N" Housing Style

Base Module	A	B	D	F	G	H	J	M	N	O	P	Q	R
<b>C002</b>	5.20	3.74	5.67	4.33	2.44	3.23	.28	1.38	.79	2.24	1.73	.16	2.17
<b>C102/C103</b>	6.93	4.65	6.97	5.91	2.76	4.02	.35	1.65	.98	2.72	2.13	.16	2.64
<b>C202/C203</b>	7.87	5.31	7.68	6.69	3.35	4.53	.43	1.97	1.18	3.39	2.56	.16	3.11
<b>C302/C303</b>	8.46	6.06	8.46	7.28	4.13	5.12 <sup>1)</sup>	.43	1.97	1.18	3.35	2.56	.16	3.11
<b>C402/C403</b>	10.04	7.09	9.65	8.66	4.33	5.71	.55	2.36	1.38	4.17	3.39	.16	4.13
<b>C502/C503</b>	11.42	7.76	11.42	9.65	5.12	6.69	.71	2.76	1.57	4.21	3.39	.16	4.25
<b>C612/C613</b>	11.81	10.43	12.40	9.65	8.46	7.87	.71	2.95	1.57	6.02	4.17	.20	5.12

<sup>1)</sup> "H" dimension on the input side of a C303 with an MR160/050 or MR160/140 is 3.66.

**Table No. 2**

Base Module	S	T	U	V	Z <sub>1</sub>	UA – Key	UB
<b>C002</b>	.43	3.62	.7500	1.57	—	$\frac{3}{16} \times \frac{3}{16} \times \frac{17}{32}$	.83
<b>C102/C103</b>	.51	4.88	1.0000	1.97	—	$\frac{1}{4} \times \frac{1}{4} \times \frac{19}{16}$	1.11
<b>C202/C203</b>	.55	5.43	1.2500	2.36	—	$\frac{1}{4} \times \frac{1}{4} \times \frac{15}{16}$	1.36
<b>C302/C303</b>	.55	5.91	1.2500	2.36	—	$\frac{1}{4} \times \frac{1}{4} \times \frac{15}{16}$	1.36
<b>C402/C403</b>	.75	6.89	1.6250	3.15	—	$\frac{3}{8} \times \frac{3}{8} \times \frac{27}{8}$	1.79
<b>C502/C503</b>	.87	7.56	1.6250	3.15	—	$\frac{3}{8} \times \frac{3}{8} \times \frac{27}{8}$	1.79
<b>C612/C613</b>	.98	6.97	2.1250	3.94	6.57	$\frac{1}{2} \times \frac{1}{2} \times \frac{35}{32}$	2.35

**Table No. 3**

"C" Series – Foot Mounting Unit Dimensions (Inches) – "N" Housing Style

Motor Adapter	NEMA C-Flange	E	X	Y	YA	YB	YC	Wt. lbs.
<b>MR140/050B</b>	56C	5.51	3.31	6.50	4.500	5.87	.41	9
<b>MR160/050B</b>	56C	6.30	3.86	6.50	4.500	5.87	.41	16
<b>MR160/140B</b>	143/145TC	6.30	3.86	6.50	4.500	5.87	.41	16
<b>MR200/180B</b>	182/184TC	7.87	4.80	9.00	8.500	7.25	.55	23
<b>MR250/180B</b>	182/184TC	9.84	5.31	9.00	8.500	7.25	.55	36
<b>MR250/210B</b>	213/215TC	9.84	5.31	9.00	8.500	7.25	.55	36
<b>MR300/180B</b>	182/184TC	11.81	6.50	9.00	8.500	7.25	.57	75
<b>MR300/210B</b>	213/215TC	11.81	6.50	9.00	8.500	7.25	.57	75
<b>MR300/250B</b>	254/256TC	11.81	6.50	9.00	8.500	7.25	.57	75
<b>MR300/280B</b>	284/286TC	11.81	6.50	11.13	10.500	9.00	.57	75

**Part No. Example**  
Beverage Duty and Food Duty  
Foot Mounting with Motor Adapter  
**C302N0620 MR160/140B**



# "C" Series—MGS Concentric/Helical Reducer Dimensional Data

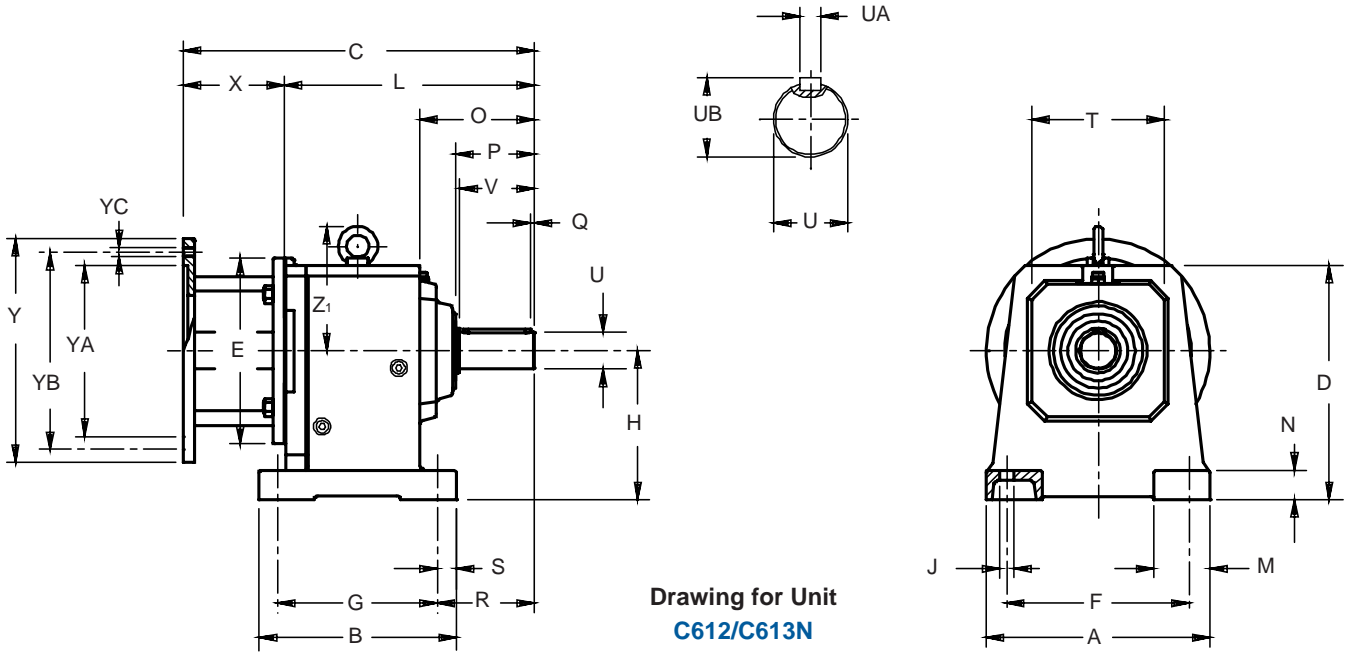
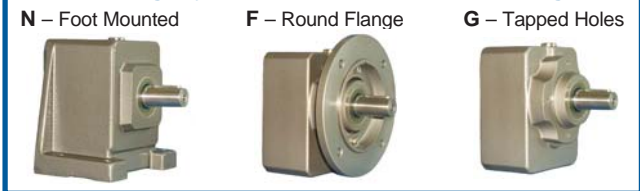

**Table No. 4 "C" Series – Foot Mounting Unit Dimensions (Inches) – "N" Housing Style**

Base Module	MR140/050B		MR160/140B <sup>2)</sup>		MR200/180B		MR250/210B <sup>3)</sup>		MR300/250B <sup>4)</sup>		Approx. Wt.(lbs.)
	C	L	C	L	C	L	C	L	C	L	
<b>C002</b>	9.37	6.06	10.08	6.22	—	—	—	—	—	—	18
<b>C102</b>	10.67	7.36	11.38	7.52	12.40	7.60	—	—	—	—	29
<b>C103</b>	12.13	8.82	—	—	—	—	—	—	—	—	34
<b>C202</b>	11.77	8.46	12.48	8.62	13.50	8.70	—	—	—	—	38
<b>C203</b>	13.23	9.92	14.17	10.31	—	—	—	—	—	—	45
<b>C302</b>	—	—	13.23	9.37	14.25	9.45	14.88	9.57	—	—	49
<b>C303</b>	13.98	10.67	14.92	11.06	—	—	—	—	—	—	56
<b>C402</b>	—	—	15.12	11.26	16.14	11.34	16.77	11.46	—	—	71
<b>C403</b>	—	—	16.81	12.95	—	—	—	—	—	—	78
<b>C502</b>	—	—	15.95	12.09	16.97	12.17	17.59	12.28	19.33	12.83	95
<b>C503</b>	—	—	17.64	13.78	—	—	—	—	—	—	111
<b>C612</b>	—	—	—	—	17.91	13.11	18.54	13.23	20.24	13.74	115
<b>C613</b>	—	—	18.62	14.76	20.35	15.55	—	—	—	—	159

- <sup>2)</sup> Also available as **MR160/050B** for a NEMA 56C frame motor. "H" dimension on the input side of a C303 with an MR160/050 or MR160/140 is 3.66.
- <sup>3)</sup> Also available as **MR250/180B** for a NEMA 182/184TC frame motor.
- <sup>4)</sup> Also available as **MR300/180B** for a NEMA 182/184TC, **MR300/210B** for a NEMA 213/215TC, and **MR300/280B** for a NEMA 284/286TC frame motor.

**Housing Style Options—See the MGS catalog.**



**Part No. Explanation**

**C 3 0 2 N 0620 MR 160/140 B**

C: Concentric Helical  
 3: Unit No.  
 0: Generation No.  
 2: "N" Housing Style (also "F", "G", "Q")  
 N: No. of Gear Reductions  
 0620: Ratio (0620 = 61.92:1)  
 MR: Motor Adapter  
 160/140: Flange No. / Motor Frame Size  
 B: Beverage Duty

Units can be mounted in any horizontal output mounting positions.

All weights are approximate.

Units listed (C102 through C613) are the standard Beverage Duty and Food Duty sizes. For larger sizes not shown, consult STÖBER Drives Inc.

# Poultry Duty "F" Series – MGS Offset Helical Reducer



- Lubricated for Life
- Maintenance Free
- Totally Enclosed (No Vent Required)
- 3 Year Warranty – your guarantee of our confidence in the MGS (Modular Gear System) line of reducers
- 97% Efficiency – for high quality and reliability plus cost savings in energy and maintenance

Standard Coating – Industrial 316 Stainless Steel Epoxy



Stainless Steel Nameplate

Double Sealed Output – with a dual lip outer seal and a single lip inner seal

Stainless Steel Output Quill



NEMA C-face Input –  
O-ring between motor and  
reducer with an easy mount,  
maintenance free coupling

Outside Cover Cap – protects seals  
from high pressure washing

MEX (55) 53 63 23 31 MTY (81) 83 54 10 18  
 QRO (442) 1 95 72 60 ventas@industrialmagza.com  
**INDUSTRIAL MAGZA**  
 DIST. AUTORIZADO

## Mounting Positions

One Standard Unit for ALL Horizontal Mounting Positions  
Without Changing the Oil Level



EL1



EL2



EL3



EL4





# Hollow Output "F" Series – MGS Offset Helical Reducer Dimensional Data

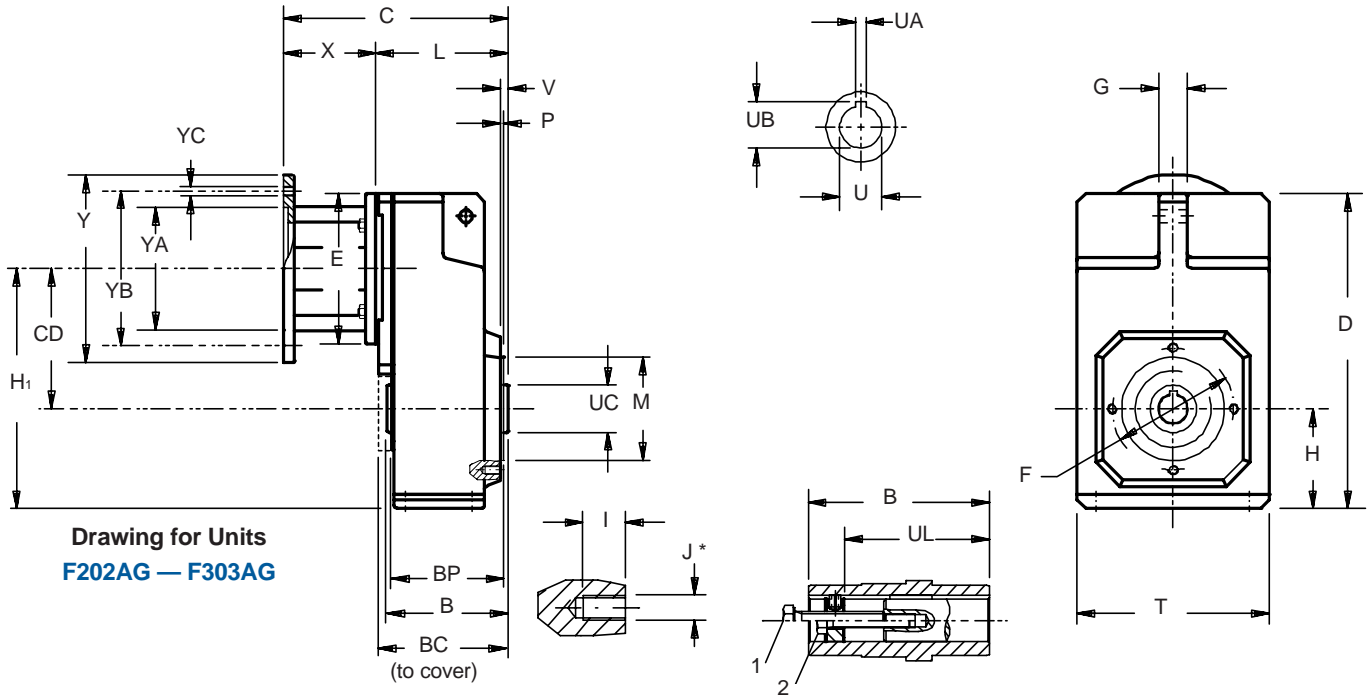

Drawing for Units  
F202AG — F303AG

Table No. 1 "F" Series – Unit Dimensions (Inches) – "G" Housing Style

Base Module	CD	B	D	F	G	H	H <sub>1</sub>	I	J*	M	P	T	U	V	BC	BP	UA	UB	UC	UL	1
F202/F203	5.16	4.53	11.77	4.53	.87	3.66	8.82	.51	M8	3.740	.12	7.09	1.0000	.31	4.76	4.13	.250	1.12	1.77	3.62	1/2-13
F302/F303	5.89	5.12	13.23	5.12	1.18	4.17	10.06	.63	M10	4.331	.14	8.11	1.2500	.33	5.45	4.72	.250	1.37	1.97	4.06	1/2-13

Table No. 2

"F" Series — Unit Dimensions (Inches) – "G" Housing Style

Motor Adapter	NEMA C-Flange	E	X	Y	YA	YB	YC	Wt. lbs.
MR140/050B	56C	5.51	3.31	6.50	4.500	5.87	.41	9
MR160/050B	56C	6.30	3.86	6.50	4.500	5.87	.41	16
MR160/140B	143/145TC	6.30	3.86	6.50	4.500	5.87	.41	16
MR200/180B	182/184TC	7.87	4.80	9.00	8.500	7.25	.55	23

Table No. 3

"F" Series Unit Dimensions (Inches)

Base Module	MR140/050B		MR160/140B <sup>1)</sup>		MR200/180B		Approx. Wt. lbs.
	C	L	C	L	C	L	
F202	8.15	4.84	8.86	5.00	9.88	5.08	51
F203	9.61	6.30	—	—	—	—	64
F302	8.74	5.43	9.45	5.59	10.47	5.67	67
F303	10.20	6.89	—	—	—	—	73

<sup>1)</sup> Also available as MR160/050B for a NEMA 56C frame motor.

**Part No. Explanation**

F 3 0 2 A G 0560 MR160/140B

- F: "G" Housing Style
- 3: "A" Hollow Output Bore
- 0: No. of Gear Reductions
- 2: Generation No.
- 0560: Unit No.
- MR160/140B: Offset Helical

143/145TC Motor Adapter  
Ratio (0560 = 56.49:1)



**Part No. Example**

Poultry Duty Unit with Motor Adapter  
F302AG0560 MR160/140B

1. Removal Bolt — not supplied.
  2. Mounting Bolt — must be smaller than removal bolt.
- All weights are approximate.

MEX (55) 53 63 23 31 MTY (81) 83 54 10 18  
 QRO (442) 1 95 72 60  
 INDUSTRIAL MAGAZA  
 DIST. AUTORIZADO  
 ventas@industrialmagaza.com

# Poultry Duty "K" Series – MGS Helical/Bevel Reducers



- Lubricated for Life
- Maintenance Free
- Totally Enclosed (No Vent Required)
- 3 Year Warranty – your guarantee of our confidence in the MGS (Modular Gear System) line of reducers
- 97% Efficiency – for high quality and reliability plus cost savings in energy and maintenance



NEMA C-face Input –  
O-ring between motor and reducer  
Easy mount, maintenance free  
coupling

Standard Coating – Industrial 316  
Stainless Steel Epoxy

Stainless Steel Nameplate

Double Sealed Output – with  
a dual lip outer seal and a  
single lip inner seal

Stainless Steel Output Quill



Outside Cover Cap – protects seals  
from high pressure washing

## Mounting Positions

One Standard Unit for ALL Horizontal Mounting Positions  
Without Changing the Oil Level



EL1



EL2



EL5



EL6

Possible but not recommended



# Hollow Output "K" Series – MGS Helical/Bevel Reducer Dimensional Data

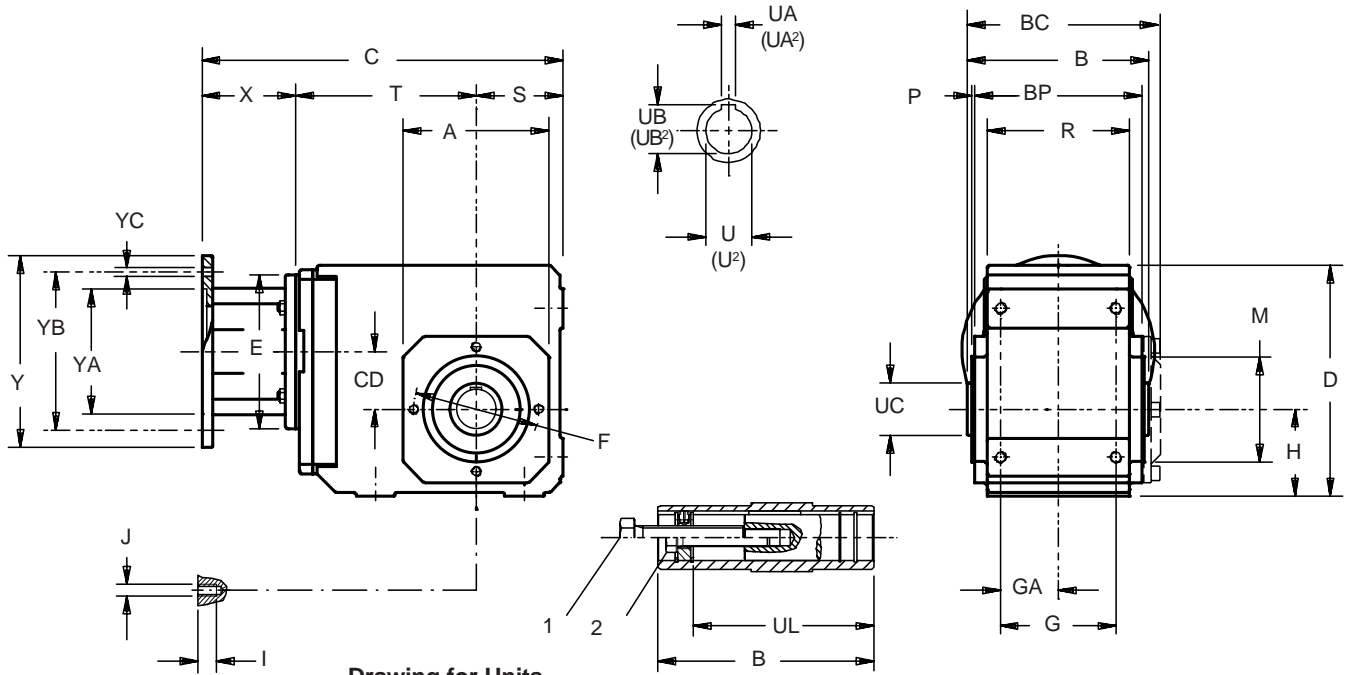

Drawing for Units  
K202AG – K403AG

Table No. 1 "K" Series – Unit Dimensions (Inches) – "G" Housing Style

Base Module	A	B	D	F	G	H	I	J	M	P	R	S	U	U <sub>2</sub>
<b>K102</b>	4.13	4.41	6.30	3.54	2.76 <sup>1)</sup>	2.36	.51 <sup>1)</sup>	M8 <sup>1)</sup>	2.953	.12	3.54	2.36	1.000	–
<b>K202/203</b>	4.57	5.83	7.48	3.94	3.54	2.56	.51	M8	3.228	.12	4.53	2.56	1.250	–
<b>K302/303</b>	5.20	6.30	8.39	4.53	4.13	2.95	.51	M8	3.740	.12	5.12	2.95	1.250	1.375

<sup>1)</sup> K102 units have mounting holes on Side 1 (top) and Side 2 (bottom).

Table No. 2

Base Module	BC	BP	GA	UA	UA <sup>2</sup>	UB	UB <sup>2</sup>	UC	UL	1
<b>K102</b>	4.85	4.17	1.38 <sup>1)</sup>	.250	–	1.11	–	1.57	3.86	1/2-13
<b>K202/203</b>	6.15	5.28	1.77	.250	–	1.31	–	1.77	4.78	1/2-13
<b>K302/303</b>	6.62	5.75	2.07	.250	.312	1.38	1.52	1.97	4.92	5/8-11

Table No. 3 "K" Series – Unit Dimensions (Inches)

Base Module	MR140/050B			MR160/140B <sup>2)</sup>			MR200/180B			Wt. lbs.
	CD	C	T	CD	C	T	CD	C	T	
<b>K202</b>	1.81	11.50	5.63	1.81	12.21	5.79	1.81	13.23	5.87	40
<b>K203</b>	1.81	12.96	7.09	–	–	–	–	–	–	53
<b>K302</b>	2.07	12.68	6.42	2.07	13.38	6.57	2.07	14.40	6.65	67
<b>K303</b>	2.07	14.13	7.87	.63	15.08	8.27	–	–	–	73

<sup>2)</sup> Also available as MR160/050B for a NEMA 56C frame motor.

Table No. 4 Motor Adapter Dimensions (Inches)

Motor Adapter	NEMA C-Flange	E	X	Y	YA	YB	YC	Wt. lbs.
<b>MR140/050B</b>	56C	5.51	3.31	6.50	4.500	5.87	.41	9
<b>MR160/050B</b>	56C	6.30	3.86	6.50	4.500	5.87	.41	16
<b>MR160/140B</b>	143/145TC	6.30	3.86	6.50	4.500	5.87	.41	16
<b>MR200/180B</b>	182/184TC	7.87	4.80	9.00	8.500	7.25	.55	23

Part No. Explanation

**K 3 0 3 A G 0650 MR160/140B**

143/145TC Motor Adapter  
Ratio (0650 = 65.5:1)  
"G" Housing Style  
"A" Hollow Output Bore  
No. of Gear Reductions  
Generation No.  
Unit No.  
Right Angle Helical/Bevel



Part No. Example

Tapped Holes Housing with Motor Adapter  
**K303AG0650 MR160/140B**

See the MGS catalog for other housing styles not shown here.

1. Removal Bolt — not supplied.
  2. Mounting Bolt — must be smaller than removal bolt.
- All weights are approximate.

# Motor Mounting Instructions MGS Speed Reducers



## Step 1.

Measure the Motor Shaft

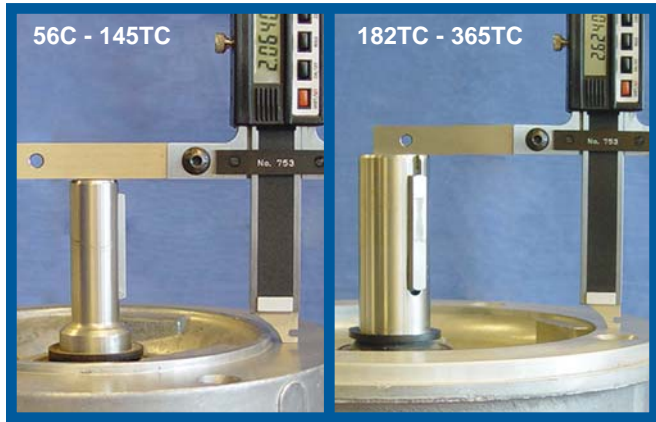

Accurate measurement of the motor shaft is vital to mounting the motor coupling correctly. The measurement must be taken from the face of the motor or pilot surface (see above) to the end of the motor shaft. If this dimension is the same as the NEMA standard "AH" dimension shown in Table No. 1, proceed with the motor mounting in Step 2.

**Table No. 1 NEMA Motor Shaft Dimensions**

Motor Frame	"AH"	Shaft Dia.	Motor Frame	"AH"	Shaft Dia.
56C	2 <sup>1</sup> / <sub>16</sub>	5/8	254/256TC	3 <sup>3</sup> / <sub>4</sub>	1 <sup>5</sup> / <sub>8</sub>
143/145TC	2 <sup>1</sup> / <sub>8</sub>	7/8	284/286TC	4 <sup>3</sup> / <sub>8</sub>	1 <sup>7</sup> / <sub>8</sub>
182/184TC	2 <sup>5</sup> / <sub>8</sub>	1 <sup>1</sup> / <sub>8</sub>	324/326TC	5	2 <sup>1</sup> / <sub>8</sub>
213/215TC	3 <sup>1</sup> / <sub>8</sub>	1 <sup>3</sup> / <sub>8</sub>	364/365TC	5 <sup>5</sup> / <sub>8</sub>	2 <sup>3</sup> / <sub>8</sub>

If the motor shaft length measurement is less than "AH", **subtract** the difference ( $\Delta_1$ ) from the "X" dimension shown in Table No. 2.

If the motor shaft length measurement is greater than "AH", **add** the difference ( $\Delta_2$ ) to the "X" dimension shown in Table No. 2.

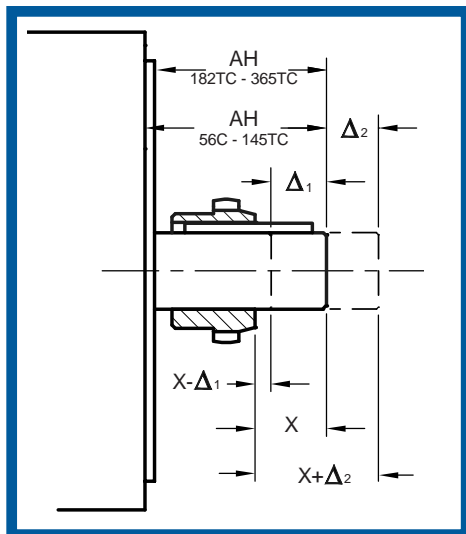

## Step 2.

Locate the Motor Coupling on the Motor Shaft

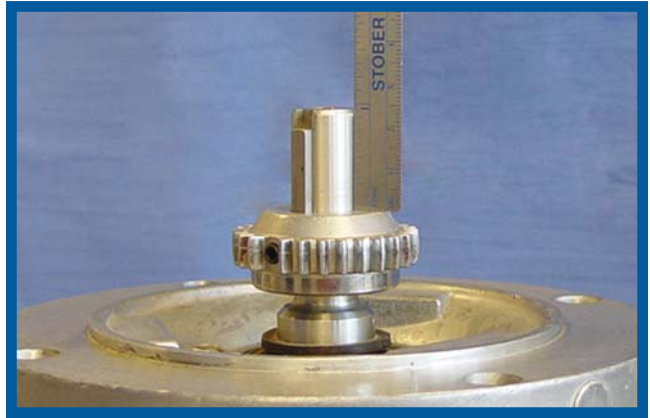

Mount the coupling with the hub projection toward the step or shoulder of the motor. The motor shaft should project through the coupling by the "X" dimension (or the value determined using the previous measurement).

**Table No. 2 Location of Motor Coupling**

Adapter Part No.	"X" mm	"X" inches	Adapter Part No.	"X" mm	"X" inches
MR140/050B	28	1.1	MR250/180B	30	1.2
MR160/050B	22	.9	MR250/210B	46	1.8
MR160/140B	25	1.0	MR300/180B	10	.4
MR200/050B	12	.5	MR300/210B	26	1.0
MR200/140B	12	.5	MR300/250B	42	1.7
MR200/180B	30	1.2	MR300/280B	58	2.3

"X" Tolerance is +1mm / -0mm (+0.040 / -0.000 inches)

## Step 3.

Tighten the Setscrew



With the coupling hub located at the correct distance, tighten the setscrew in the coupling.





# Motor Mounting Instructions

## MGS Speed Reducers

### Step 4.

Secure the Motor Shaft Key



For ease of installation, secure the motor shaft key. Staking near the end of the keyway, on the sides of the key, or a temporary adhesive works well.

### Step 5.

Mount the Motor

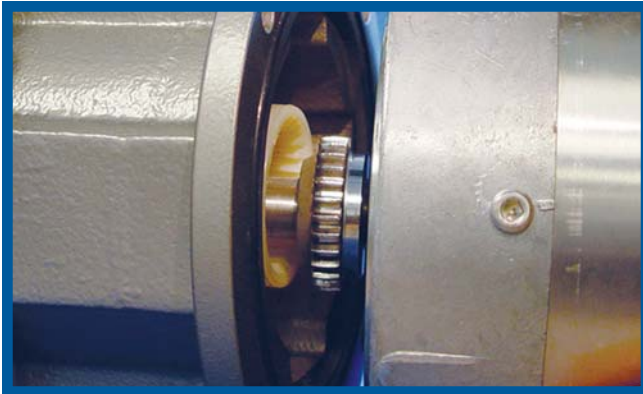

With the coupling secure, insert the motor shaft into the motor adapter. The coupling sleeve is already installed on the mating reducer coupling hub inside the motor adapter. **The sleeve should move freely in an axial direction.** (Axial displacement  $\pm 0.040$  inches.)

With the motor in place, tighten the motor bolts.

#### CAUTION:

IF THE MOTOR COUPLING IS NOT INSTALLED CORRECTLY, THE INPUT BEARING MAY FAIL DUE TO PRE-LOAD. THIS WILL VOID THE WARRANTY OF THE REDUCER AND POSSIBLY FAIL THE MOTOR.

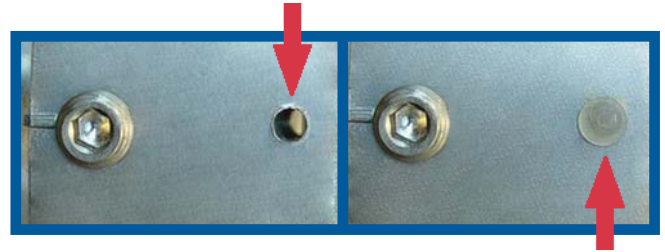

Some motor manufacturers provide a drain hole in the mounting face of washdown motors. In some mounting positions, water or other material can enter the motor adapter and fail the bearing.

Be sure this hole is covered during washing or when the unit is in a wet environment. The illustration shows the method that STÖBER assembly personnel uses to plug the hole.

Shown in Table No. 1 is the motor coupling hub and sleeve part number for the STÖBER MGS® motor adapter. These parts, with a coupling shaft component that is part of the reducer, make a complete coupling to connect the motor to the reducer.

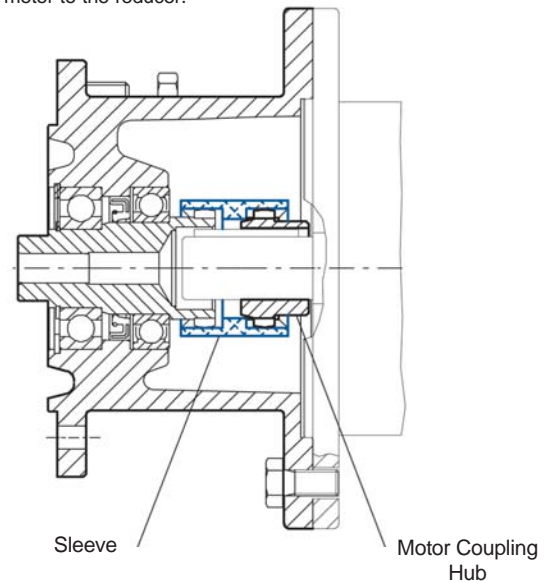

Table No. 1

#### Couplings Used with MR Motor Adapters

Adapter	NEMA Frame	Motor Hub	Sleeve
MR140/050B	56C	M-19 x 5/8	M-19
MR160/050B	56C	M-24 x 5/8	M-24
MR160/140B	143/145TC	M-24 x 7/8	M-24
MR200/050B	56C	M-32 x 5/8	M-32
MR200/140B	143/145TC	M-32 x 7/8	M-32
MR200/180B	182/184TC	M-32 x 1 1/8	M-32
MR250/180B	182/184TC	M-38 x 1 1/8	M-38
MR250/210B	213/215TC	M-38 x 1 3/8	M-38
MR300/180B	182/184TC	M-48 x 1 1/8	M-48
MR300/210B	213/215TC	M-48 x 1 3/8	M-48
MR300/250B	254/256TC	M-48 x 1 3/8	M-48
MR300/280B	284/286TC	M-48 x 1 7/8	M-48



# Terms and Conditions of Sale



1. **GENERAL.** All orders for products supplied by STOBER DRIVES INC. ("Stober") shall be subject to these terms and conditions of sales. All transactions shall be governed by the laws of the Commonwealth of Kentucky. No modifications hereto will be binding unless agreed to in writing by Stober.

2. **CUSTOMER.** The term "Customer," as used herein, means the distributor, resale dealer, original equipment manufacturer or first end-user customer that purchases the Stober products.

3. **WARRANTY.** Stober products shall be free from defects in material and workmanship for a maximum of 5-years (single shift operation) or 30 months (multiple shift operation) for ServoFit products; 3-years (single shift operation) or 18 months (multiple shift operation) for MGS products; 2-years (single shift operation) or 12 months (multiple shift operation) for TD products, from the date of shipment to the Customer. For ServoFit products, all normal wear items, including oil seals and bearings, shall be covered for a period of 2-years (single shift operation or 12 months multiple shift operation). In the event that a product proves to be defective, Stober's sole obligation shall be, at its option, to repair or replace the product. The repaired or replacement product will be shipped F.O.B. Stober's facilities, freight prepaid by Stober.

No employee, agent or representative of Stober has the authority to waive, alter, vary or add to the terms hereof without the prior written approval of an officer of Stober. It is expressly agreed that (a) this section constitutes the final expression of the parties' understanding with respect to the warranty and (b) this section is a complete and exclusive statement of the terms of the warranty.

Stober shall have no obligation under the warranty set forth above in the event that:

- The Customer fails, within the warranty period to notify Stober in writing and provide Stober with evidence satisfactory to Stober of the alleged defect within five (5) days after it becomes known to the customer;
- After inspection of a product, Stober determines, in its sole discretion, that it is not defective in material or workmanship;
- Repair or replacement of a product is required through normal wear and tear;
- Any part in a product or any ingredient contained in a product requires replacement or repair through routine usage or normal wear and tear;
- A product is not maintained or used in accordance with Stober's applicable operating and/or maintenance manuals, whether by the Customer or any third party;
- A product has been subject to misuse, misapplication, negligence, neglect (including, but not limited to, improper maintenance or storage), accident, catastrophe, improper installation, modification, adjustment, repair or lubrication, whether by the Customer or any third party, without the prior written consent of Stober. Misuse shall include, but not be limited to, deterioration in a product due to chemical action and wear caused by the presence of abrasive materials;
- The system of connected rotating parts into which the product becomes incorporated is not compatible with the product, or it is not free from critical speed or torsional or other type of vibration within the specified operating range, no matter how induced; or
- The transmitted load and imposed torsional thrust and overhung loads are not within the published capacity limits for the unit sold.

Items manufactured by other parties but installed in or affixed to Stober's products are not warranted by Stober and bear only those warranties, express or implied, which are given by the manufacturer of such items, if any.

THE WARRANTY SET FORTH ABOVE IS INTENDED SOLELY FOR THE BENEFIT OF THE Customer AND DOES NOT APPLY TO ANY THIRD PARTY. ALL CLAIMS MUST BE MADE BY THE Customer AND MAY NOT BE MADE BY ANY THIRD PARTY. THIS WARRANTY MAY NOT BE TRANSFERRED OR ASSIGNED, IN WHOLE OR IN PART, BY THE Customer FOR ANY REASON WHATSOEVER. ANY SUCH ATTEMPTED TRANSFER OR ASSIGNMENT SHALL BE NULL AND VOID.

THIS WARRANTY TAKES THE PLACE OF ALL OTHER WARRANTIES, EXPRESS OR IMPLIED, WHICH ARE HEREBY DISCLAIMED AND EXCLUDED BY STOBER, INCLUDING WITHOUT LIMITATION, ANY WARRANTY OF MERCHANTABILITY OR FITNESS FOR A PARTICULAR PURPOSE OF USE AND ALL OBLIGATIONS OR LIABILITIES ON THE PART OF STOBER FOR DAMAGES ARISING OUT OF OR IN CONNECTION WITH THE USE, REPAIR OR PERFORMANCE OF THE PRODUCTS.

4. **MODIFICATIONS.** Stober reserves the right, without notice to the Customer, to (a) change the specifications of any product, (b) improve a product in any manner that Stober deems necessary or appropriate and (c) discontinue the manufacture of any product.

5. **PURCHASE ORDERS.** The Customer will submit purchase orders for the products to Stober in writing, whether by mail or telefax, which shall set forth, at a minimum: (a) an identification of the products ordered, (b) prices for such products, (c) quantities, (d) requested delivery dates and (e) shipping instructions and shipping addresses.

6. **ACCEPTANCE OF ORDERS.** All purchase orders received from the Customer are subject to acceptance by Stober in writing.

7. **MODIFICATION OF ORDERS.** No accepted purchase order shall be modified or canceled except upon the written agreement of Stober and the Customer. Mutually agreed cancellations shall be subject to reasonable charges based upon expenses already incurred by Stober and commitments made by Stober. Mutually agreed change orders shall be subject to all provisions of these Terms and Conditions of Sale.

8. **PRICE INCREASES.** Stober may increase its prices for the products by providing the original purchaser of the products with at least thirty (30) days' prior written notice. Increased prices for products shall not apply to purchase orders accepted prior to the effective date of the price increase unless such orders provide for delivery more than thirty (30) days after the date of acceptance of the order.

9. **PRICING AND DELIVERY TERMS.** In accordance with KRS 355.2-319(1)(b), all products are delivered F.O.B. Stober's warehouse facility in Maysville, Kentucky, or such other facility as Stober may designate. Orders are then shipped per Customer's shipping instructions as set forth in Customer's purchase order. **CATALOG PRICING DOES NOT INCLUDE SHIPPING, HANDLING AND TAXES.** Once delivered to a common carrier of the Customer's choosing [or of Stober's choosing if Customer has failed to specify a common carrier on or before five (5) days prior to the requested delivery date] Stober shall have no further responsibility for the products and all risk of damage, loss or delay shall pass to the Customer. A handling fee is added to freight costs by Stober to cover the cost of having to pay the carrier within seven (7) days when the terms with the Customer are net 30. The Customer has the option of shipping collect with our carrier or the carrier of choice.

10. **PAYMENT TERMS.** Net 30 days. All orders will be shipped either prepaid by the Customer or C.O.D., at Stober's option, unless the Customer has established a previously approved credit line. If Stober approves a credit line for the Customer, all payments shall be due within thirty (30) days of the date of the invoice. If any invoice is not paid in full within such thirty (30) day period, then finance charges shall be assessed at the

rate of one and one-half percent (1½%) per month (eighteen percent (18%) per year). If such rate is deemed to be usurious at any time, it shall be reduced to the maximum rate permitted by applicable law. Stober may stop or withhold shipment of products if the Customer does not fulfill its payment obligations. If Stober is insecure about payment for any reason, Stober may require full or partial payment in advance and as a condition to the continuation of its delivery of products.

11. **SECURITY INTEREST.** Unless and until the products are paid for in full, Stober reserves a security interest in them to secure the unpaid balance of the purchase price. The Customer hereby grants to Stober a power of attorney, coupled with an interest, to execute and file on behalf of the Customer all necessary financing statements and other documents required or appropriate to protect the security interest granted herein.

12. **ACCEPTANCE OF PRODUCTS.** The Customer will conduct any incoming inspection tests as soon as possible upon arrival of the products, but in no event later than ten (10) days after the date of receipt. Any products not rejected by written notice to Stober within such period shall be deemed accepted by the Customer. Stober shall not be liable for any additional costs, expenses or damages incurred by the Customer, directly or indirectly, as a result of any shortage, damage or discrepancy in a shipment.

13. **LIMITATION OF REMEDIES.**

- STOBER SHALL NOT BE LIABLE FOR ANY LOSS OR DAMAGE CAUSED BY DELAY IN FURNISHING THE CUSTOMER WITH PRODUCTS.
- IN NO EVENT SHALL STOBER'S LIABILITY INCLUDE ANY SPECIAL, INDIRECT, INCIDENTAL OR CONSEQUENTIAL LOSSES OR DAMAGES, EVEN IF STOBER HAS BEEN ADVISED OF THE POSSIBILITY OF SUCH POTENTIAL LOSS OR DAMAGE.

14. **MADE-TO-ORDER PRODUCTS.** Stober reserves the right to revoke and amend any price quotations offered to the Customer for made-to-order products, provided that such price quotations have not been accepted by the Customer prior to the date of revocation or amendment.

15. **DIES, TOOLS AND EQUIPMENT.** Charges incurred by the Customer for dies, tools and other equipment shall not confer ownership or the right to possession therein by the Customer. All such dies, tools and equipment shall remain the property of Stober, and Stober shall have the exclusive right to possession thereof. Stober shall maintain such tools and equipment in good working order.

16. **REGULATORY LAWS AND STANDARDS.** Stober makes no representation that its products conform to state or local laws, ordinances, regulations, codes or standards except as may be otherwise agreed to in writing by Stober.

17. **SIZES AND WEIGHTS.** Stober's products are made only in the sizes and to the specifications set forth in its catalogs and other literature. If any alteration is requested, such altered product will be treated as a made-to-order item. Stober assumes no responsibility for typographical errors which may appear in its catalogs or literature, and cannot accept alteration charges caused by such errors. Since weights shown in Stober's catalogs are approximate, they cannot be used in determining freight allowances set forth in its catalogs and other literature. Freight allowances will be determined at the time of shipment and shall be based on actual shipping weight.

18. **SYSTEM DESIGN.** Responsibility for system design to ensure proper use and application of Stober's products within their published specifications and ratings rests solely with the Customer. This includes, but is not limited to, an analysis of loads created by torsional vibrations within the entire system, regardless of how induced.

MEX (55) 53 63 23 31 MTY (81) 83 54 10 18  
ORO (442) 1 95 72 60 ventas@industrialmagza.com

